

**An Evaluation of Silica Exposure Controls for
Tuckpointing: DustControl 2900c Vacuum with the ICS
Dust Director Shroud and Bosch Grinder Model 1775E
Conducted November 14-15, 2012**



**CPWR – The Center for
Construction Research and Training**

Michael R. Cooper, MPH, CIH, CSP

Pam Susi, MSPH, CIH

April 15, 2014

LEV-E-TP2

© 2014, CPWR – The Center for Construction Research and Training. CPWR, the research and training arm of the Building and Construction Trades Dept., AFL-CIO, is uniquely situated to serve construction workers, contractors, practitioners, and the scientific community. This report was prepared by the authors noted. Funding for this research study was made possible by a cooperative agreement with the National Institute for Occupational Safety and Health, NIOSH (OH009762). The contents are solely the responsibility of the authors and do not necessarily represent the official views of NIOSH or CPWR.

Executive Summary

This report describes the results of an evaluation, in a controlled setting, of a tuckpointing dust control system consisting of **a Bosch model 1775E grinder, a Dust Director shroud, and a DustControl 2900c vacuum**. Removing mortar with a Bosch grinder without the dust control system resulted in a mean task time-weighted average (TWA) respirable silica exposure 145 times the National Institute for Occupational Safety and Health (NIOSH) Recommended Exposure Limit (REL) of 0.05 mg/m³ for respirable silica. Use of the same grinder with the dust control system reduced exposures by approximately 99 percent. However, exposures measured during use of the dust control system still exceeded the selected occupational exposure limit. It should also be noted that the NIOSH REL is based on exposures averaged over a ten hour work day and our results represent time weighted averages of the sample task duration periods.

ACRONYMS

ACGIH	American Conference of Governmental Industrial Hygienists
CPWR	CPWR – The Center for Construction Research and Training
Ce	coefficient of entry
HEPA	high-efficiency particulate air
IUBAC	International Union of Bricklayers and Allied Craftworkers
LEV	local exhaust ventilation
PACT	Partnership for Advancing Control Technologies
NIOSH	National Institute for Occupational Safety and Health
OEL	occupational exposure limit
OSHA	Occupational Safety and Health Administration
PAPR	powered air-purifying respirator
PEL	permissible exposure limit
PVC	polyvinyl chloride
REL	recommended exposure limit
RPM	revolutions per minute
TWA	time-weighted average
SP	static pressure

I. Introduction and Background

In 2010 CPWR – The Center for Construction Research and Training began a four-year project which seeks to identify and evaluate tuckpointing local exhaust ventilation (LEV) systems and disseminate information on their availability and effectiveness. A Partnership for Advancing Control Technologies (PACT) comprised of masonry contractors, representatives from unions, government, equipment manufacturers, and health and safety researcher was formed as part of this project. PACT members participated in identifying important characteristics for control technologies and this information was used to identify LEV systems for tuckpointing using that criteria. Contractor and labor members of the PACT selected specific tuckpointing LEV systems to be considered for evaluation. Each system consisted of a tuckpointing grinder, shroud, and vacuum. This report describes the second of four systems to be evaluated between 2012 the end of 2014, with and without LEV, in a controlled setting to determine effectiveness in silica exposure reduction. This report describes the methods and results of our evaluation of a system consisting of the **DustControl 2900c vacuum with the ICS Dust Director shroud and a Bosch Model 1775E grinder.**

Excessive exposure to respirable silica can result in silicosis or other silica-related diseases including pulmonary tuberculosis, lung cancer, silicoproteinosis (Lyons et al, 2007) and autoimmune disorders such as rheumatoid arthritis, sarcoidosis and scleroderma (Miller et al, 2012). Respirable silica is generally defined as particles less than 10 micrometers (μm) in aerodynamic diameter (ACGIH, 2013). Silicosis can lead to symptoms including shortness of breath, fatigue, chest pains, susceptibility to infection and possibly death. There is no cure for silicosis, however it is totally preventable. Construction workers exposed to dust, including silica, are also known to have higher rates of chronic obstructive pulmonary disease (COPD).

There are many sources of silica in construction that result in exposures of varying intensity among workers. Masonry restoration workers are among the most highly silica-exposed trades in construction. The process of grinding out deteriorated mortar joints between masonry units and replacing or repointing with fresh mortar (often referred to as tuckpointing) is a fundamental part of masonry restoration work. The removal of mortar with powered angle grinders generates enormous levels of dust. Between 2004 and 2006, NIOSH and CPWR evaluated silica exposures while grinding mortar in a controlled setting, at a local training center, where tasks, sample times and task variables were defined by the study design. These studies demonstrated that grinding mortar without controls can result in elevated respirable silica exposures. Meeker et al., (2009) reported exposures between 5 and 25.8 milligrams per cubic meter (mg/m^3) in a controlled setting. This study also showed that LEV systems for tuckpointing grinders can reduce exposures to respirable silica by greater than 90 percent.

II. Objectives

The objective of this evaluation was to assess the effectiveness of an LEV system for controlling exposure to silica during the grinding of mortar. The control technology was tested under controlled conditions, similar to those experienced by tuckpointers on actual job sites, using journeymen bricklayers experienced in tuckpointing and repeat, randomized trials with and without LEV. All other variables were held constant throughout so that the only variable was whether or not the tested control was used.

III. Description of Equipment Tested

A **Bosch model 1775E** grinder (Robert Bosch Tool Corporation, Prospect, IL) (**Figures 1, 2 and 3**) was fitted with a new 1/4-inch wide, 4½-inch diameter segmented diamond abrasive blade made by DeWalt (model #DW4740). The grinder weighs six and a half pounds, draws 8.5 amps and has a variable speed up to 11,000 revolutions per minute (RPMs). The **DustControl 2900c vacuum** (DustControl, Inc., Wilmington, NC) (**Figure 3**) was tested in combination with the **Dust Director shroud** (Industrial Contractors' Supplies, Inc., Huntingdon, PA) (**Figures 1 and 3**) attached to the Bosch grinder.



Figure 1. Bosch grinder with Dust Director shroud

The vacuum is specified to weigh **31 pounds** when empty and to provide a flow rate of 114 cubic feet of air per minute and a “static lift” or “vacuum suction pressure” of 84 inches of water. The vacuum is sold with a cyclonic pre-separator, to remove larger particles, a fine filter (rated 99.9 percent efficient) and a HEPA (high-efficiency particulate air) filter (rated

to capture 99.97 percent of the particles with an aerodynamic diameter of 0.3 micrometers). The HEPA filter was removed based on the manufacturer's recommendation due to the heavy dust loading associated with tuckpointing. CPWR sponsored research and contractor experience indicate that HEPA filters likely have an adverse effect on dust capture during tuckpointing because of extreme dust loading on filters. While the cyclone and the fine filter remove most of the dust, especially the large particles, before they reach the HEPA filter, the HEPA filter would still be subject to heavy loading, causing a substantial pressure drop and subsequent decrease in air flow rate. The relatively small increase in the efficiency of the filtration system while using the HEPA filter is expected to be quickly offset by a more significant decrease in capture efficiency as the air flow rate and ability to capture particles decreases.



Dust collects in relatively inexpensive, heavy-gauge plastic bags below and outside of the cyclone. The bags can be removed and replaced without opening the vacuum. Some vacuums are equipped with a light to indicate that the filters need to be cleaned or changed. The DC2900c features a “reverse air pulse cleaning system,” which removes accumulated dust from the filters without having to remove them from the vacuum. The system, as illustrated in **Figure 4**, requires the operator to disconnect the hose from the shroud, place it over an air stop so that air through the hose is cut off and pressure in the vacuum is maximized.

Figure 2. Bosch grinder without tuckpointing LEV system.

The flap covering the port on the side of the vacuum is repeatedly flipped open to release built up pressure in strong pulses that dislodge dust from the filter.

The manufacturer indicates “the filter is generally cleaned once or twice daily during normal continuous operation.” The Dust Director shroud has a 2-inch diameter take-off that was connected to the antistatic, corrugated 1.5-inch diameter, 15-foot long vacuum hose supplied with the DustControl vacuum.



Figure 3: Bosch Grinder with LEV System

IV. Study Methods

This evaluation was conducted at the International Union of Bricklayers and Allied Craft workers (IUBAC) Local 1 Philadelphia/Delaware Training Center in Philadelphia, PA on November 14 and 15, 2012. A single journeyman bricklayer, experienced in tuckpointing, used the grinder and LEV system being tested to remove mortar from joints wide enough to require two passes. The type S mortar had been allowed to cure for at least four weeks. The bricklayer either possessed or was provided with personal protective equipment including sturdy work boots, gloves, hearing protection and a powered air-purifying respirator (PAPR). The PAPR was a 3M GVP system with a bump cap, loose fitting face piece and a HEPA filter (3M, St Paul, MN).

The study was designed to include at least five rounds of sampling during mortar removal. Each round included a trial using the Bosch grinder with a Dust Director shroud and Dust Collector 2900c vacuum and a trial using the Bosch grinder with the factory-supplied guard and without a vacuum. The order of the two trials within each round was randomly selected to minimize bias that might be introduced due to variation associated with environmental factors, equipment operator, blade wear, vacuum performance over time and any other factors unrelated to LEV use. Tools were operated for approximately 16 minutes per trial with controls and for approximately 8 minutes when controls were not used. These times were selected based on the results of previous sampling efforts and estimates of the minimum sample time needed to achieve a limit of quantification low enough to accurately measure exposures down to or less than 0.05 mg/m^3 – the NIOSH

Recommended Exposure Limit (REL) for respirable silica. The bricklayer was required to take a 5 to 10 minute break in the middle of the 16-minute trials to reduce differences in fatigue, compared to the 8-minute trials. Personal air samples were collected in the breathing zone of the operator during each trial to measure respirable silica concentrations during grinding with and without LEV. The samples were collected using a GilAir-5 pump (Sensidyne, Inc., Clearwater, FL) to draw 4.2 liters of air per minute through a GK2.69 Respirable Cyclone (BGI Inc., Waltham, MA) with a pre-weighed, 37 mm diameter, 5-micron pore size polyvinyl chloride (PVC) filter positioned on the operator's lapel.

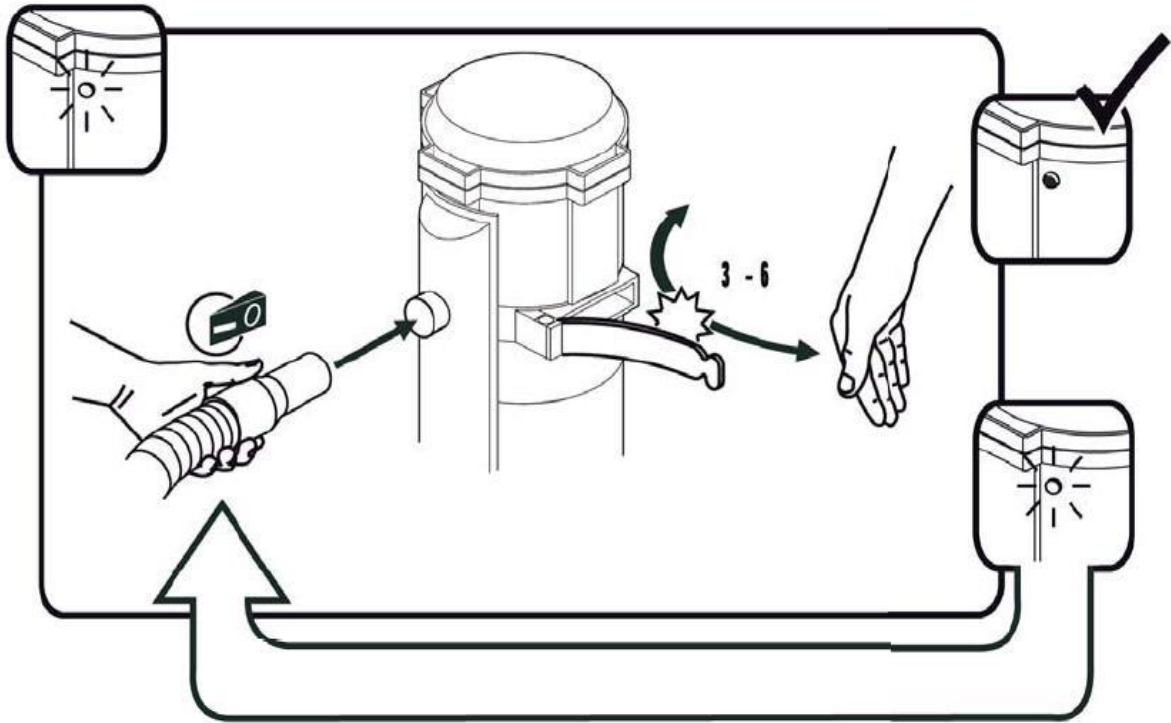

Figure 4. Procedure for "cleaning" of or dust removal from filters (source: <http://dustcontrolusa.com/manuals/2800c.pdf>)

The flow rates of the sampling pumps were calibrated at the beginning of each day using a DryCal DC-Lite Primary Flow Meter (Bios International Corporation, Butler, NJ). Flow rates were measured again near the middle and at the end of each day to ensure that sampling flow rates were maintained within 5% of pre-sampling flow rates throughout the day. Average flow rates were used to calculate sample air volumes. Samples were analyzed by R.J. Lee Group, Inc., (Monroeville, PA) using NIOSH Method 0600, to determine exposure to total mass of respirable dust. The same samples were also analyzed using X-Ray diffraction following NIOSH method 7500 to determine quartz, cristobalite and tridymite concentration in the respirable mass. Reported masses for these analytes were used with the sample air volumes to calculate airborne concentrations of total respirable dust, quartz, cristobalite and tridymite.

We used a reduction of greater than 50 percent in respirable silica exposure concentrations or a reduction to less than the NIOSH REL of 0.05 mg/m³ as our criteria for determining whether or not a control was considered efficacious. This is consistent with criteria used by NIOSH in conducting a similar study in 2004 described by Echt et al. (2007) and by CPWR in 2006 and described by Meeker et al. (2009). The Occupational Safety and Health Administration (OSHA) and the American Conference of Governmental Industrial Hygienists (ACGIH) publish additional occupational exposure limits (OELs) for silica which are listed in **Table 1** with NIOSH RELs. OELs for silica are based on the respirable fraction of the aerosol, which consists of particles less than 10 µm in aerodynamic diameter.

Table 1. Occupational Exposure Limits for Respirable Crystalline Silica

Organization or Agency	Form of Crystalline Silica	Occupational Exposure Limits (mg/m³)
NIOSH^A	Quartz	REL = 0.05 mg/m ³
	Cristobalite	REL = 0.05 mg/m ³
	Tridymite	REL = 0.05 mg/m ³
OSHA - Construction^B	Quartz	PEL = 250 / (5 + % quartz)
	Cristobalite	PEL = 250 / (5 + % cristobalite)
	Tridymite	PEL = 250 / (5 + % tridymite)
ACGIH	Crystalline Silica	TLV = 0.025 mg/m ³

^A NIOSH Publication No. 2005-151 indicates 10-hour time-weighted average during a 40-hr workweek

^B The PEL for silica in OSHA’s Safety and Health Regulations for Construction, 29 C.F.R. 1926.55(a), is an 8-hour time-weighted average (TWA) expressed in millions of particles per cubic foot (mppcf). However, the units mppcf can be converted to milligrams per cubic meter can by dividing mppcf by 10 (OSHA, 2009). The formula used by OSHA to determine the PEL for silica is dependent on the percentage of silica in each collected sample. The concentration of respirable dust measured is compared to the sample specific PEL to determine if the PEL has been exceeded. OSHA has proposed lowering the PEL to 0.05 mg/m³ of respirable silica as an 8 hour TWA.

The flow of air in ventilation systems is governed by fundamental principles that describe the behavior of gases (in this case air). Pressure measurements taken within a ventilation system along with knowledge of hood (or shroud) entry losses can be used to calculate flow rates. Hood entry losses are dependent on the shape and configuration of a particular hood or shroud and described by the term “coefficient of entry (Ce)” which is the ratio of *actual* air flow through a hood and what the air flow would *theoretically* be if there were no hood entry losses. Given the coefficient of entry, static pressure measurements can be used to calculate air flow through a given hood. The coefficient of entry for the Dust Director shroud was previously determined by CPWR and used for calculating air flow based on static pressure measurements (Meeker et al., 2009). Static pressure, with the vacuum operating, was measured periodically throughout the evaluation to monitor the changes in air-flow rate following use and again after filter cleaning. The static pressure was measured at a port positioned more than 3 duct diameters downstream from the tool’s air intake using a UEi EM200 Electronic Manometer (Universal Enterprises, Inc., Beaverton, OR).

The dust in the vacuum bag was monitored and, per the manufacturer’s instructions, the bag was changed before the dust level was within 5 centimeters of the valve at the bottom of the vacuum. Each time a vacuum bag was removed, it was weighed to the nearest pound. The bag weights and corresponding grinding durations were used to calculate the average weight of dust collected per unit time. After each trial, cut lengths were measured on the wall to determine total linear feet of vertical (head) and horizontal (bed) joints per unit time.

A Haz-Dust III, Model HD-1003, Real-Time Aerosol Monitor (Environmental Devices Corporation, Plaistow, NH) was used to confirm clearance of dust between trials. The Haz-Dust monitor was positioned on the test wall near the operator at approximately breathing zone level and configured to measure respirable particulate concentration.

V. Results

Personal air monitoring. Five pairs of respirable dust samples were collected while grinding with and without the vacuum system. In addition, three respirable dust samples were collected while grinding without the LEV system and with the stock blade guard in place. One measurement collected while grinding without the LEV system and with the stock blade guard was shown to be a statistical outlier and was omitted from analysis. Personal air monitoring results for respirable silica and a comparison of average exposures relative to the NIOSH REL for silica (0.05 mg/m³) appears in **Table 2**. The mean respirable dust levels measured without LEV was 31.4 mg/m³. However, samples collected with LEV were below the limit of quantification (LOQ) which ranged from <1.29 to <1.46 mg/m³. Use of LEV resulted in a greater than 95% reduction in mean respirable dust levels using a mean value with use of LEV of <1.41 (n=5 samples with use of LEV and n=7 without use of LEV). The respirable dust samples collected during grinding without the LEV system contained an average of 24 percent silica. The mass of respirable dust in the samples collected with use of the LEV system was too low to determine the silica content.

Table 2. Respirable Silica Exposures While Grinding Mortar^A

	Mean, mg/m ³ (range)	Std. Dev.	Percent Reduction	Hazard Ratio ^B
Bosch with Dust Director Shroud and DustControl 2900c Vacuum	0.091 (<0.069 - 0.137)	0.027	98.7	1.81
Bosch with no Control	7.23 (4.57 – 9.90)	1.94	NA	145

^A n = 5 samples with the use of the LEV system and n = 7 samples without the use of the LEV system

^B Hazard Ratio = measured exposure/NIOSH REL of 0.05 mg/m³

Average respirable silica and dust exposures, with and without the dust control system, appear as **Figures 5 and 6**, respectively.

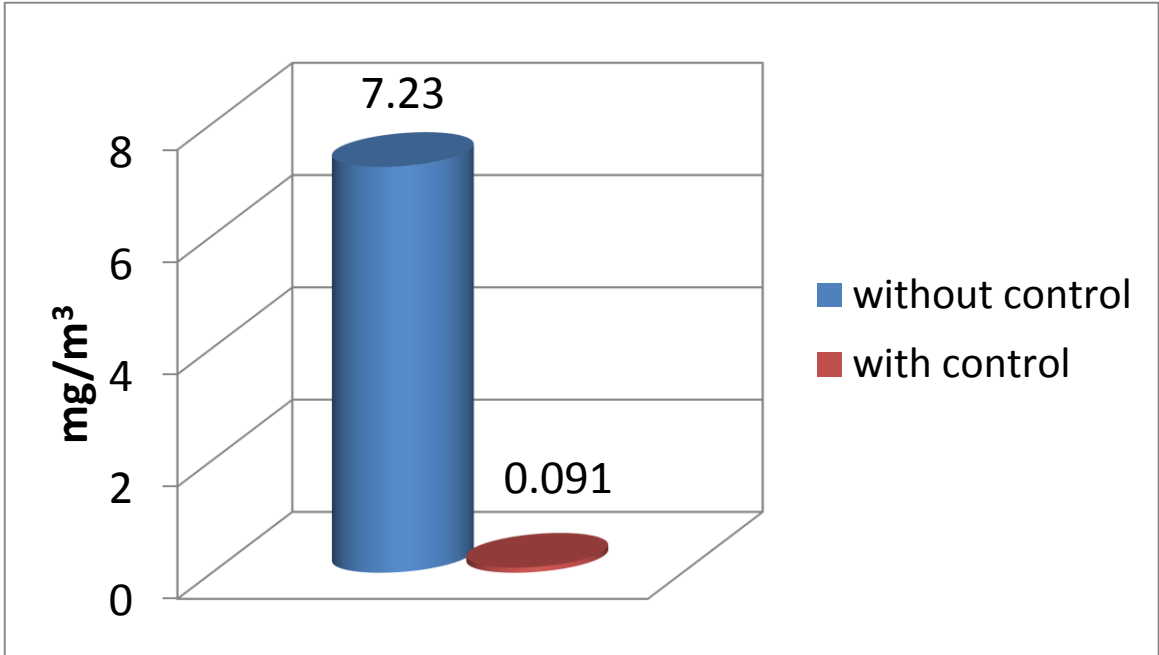

Figure 5. Average respirable silica exposures with and without the Dustcontrol 2900c vacuum and Dust Director shroud (milligrams per cubic meter of air - mg/m³)

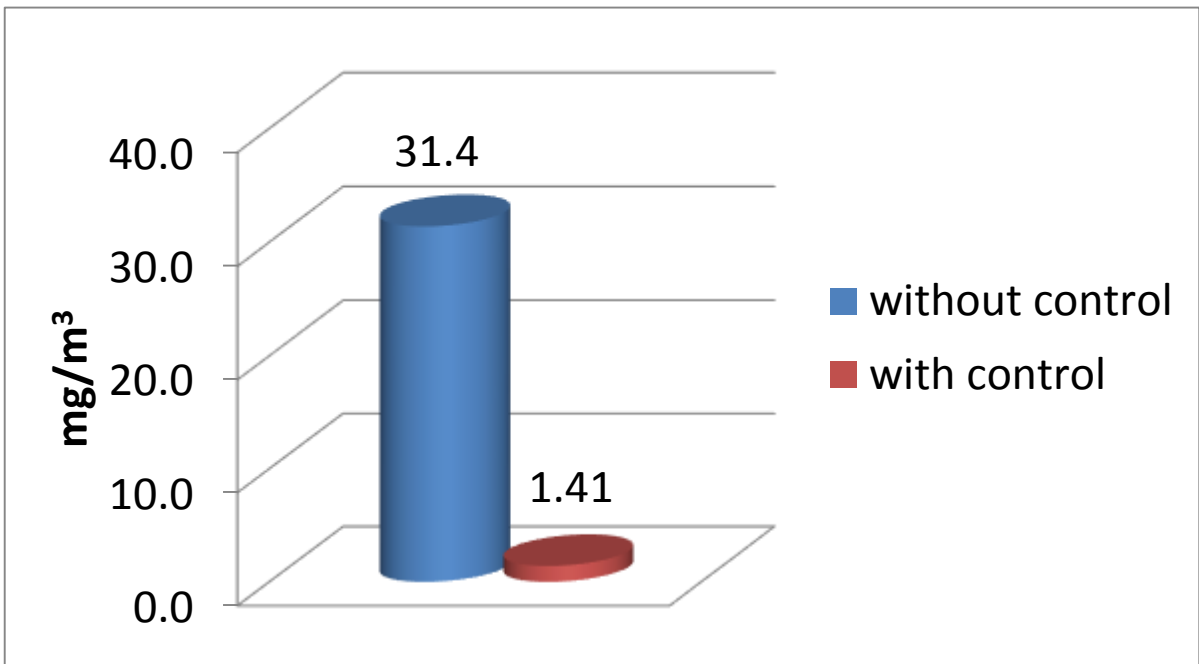

Figure 6. Average respirable dust exposures with and without Dustcontrol 2900c Vacuum and Dust Director Shroud (milligrams per cubic meter of air - mg/m³)

The mean respirable silica concentration measured during use of the control was significantly less than the concentration measured while using the same tool without controls ($p < 0.01$). Grinding mortar with the Bosch angle grinder without dust controls resulted in an average exposure to respirable silica that was **145 times the NIOSH REL**. Grinding with the Bosch angle grinder in combination with the Dust Director shroud and the DustControl 2900c vacuum reduced the average concentration of respirable silica by 98.7 percent. With use of these controls, the concentration of respirable silica was 1.8 times greater than the NIOSH REL of 0.05 mg/m^3 . However the NIOSH REL is based on a time-weighted average (TWA) over a 10-hour workday. Given these were *task* TWAs and samples were collected over continuous periods of grinding, they may overestimate exposures over an actual work day since some time would be spent performing tasks that would likely have lower, or no, silica exposures (setup, breaks, cleanup, etc.).

Static pressure, dust mass collection and grinding rates. Static pressure was used as a surrogate for air flow as described earlier. Hood static pressure was measured periodically at a tap near the grinder more than 3 duct diameters from the air intake in the shroud. The static pressure, and thus air flow, was generally higher when the vacuum's filter had recently been cleaned. The mean, median, and range of calculated flow rates are presented in **Table A1 of the Appendix**.

Based on the data we collected, the air-flow rate upstream from the Bosch grinder and Dust Director shroud ranged from 78 to 93 cubic feet per minute (cfm) with the DustControl vacuum. When the manufacturer's filter cleaning procedure was followed the vacuum performed relatively well and flow could be maintained at slightly less than 90 cfm with cleaning. However, mean flow rates dropped substantially to 80 cfm after as little as 8 minutes of grinding without any filter cleaning. The flow rate returned to an average of 89 cfm when filters were cleaned correctly (without stopping air flow to the vacuum). Collingwood and Heitbrink (2007) found that the minimum exhaust flow rate for capture of silica and other particulate under ideal conditions is 21.25 cfm per inch of grinder blade diameter. This is equal to about 96 cfm when using a 4.5 inch diameter grinding blade. We set 106 cfm as the minimum desired flow rate for this study to allow a safety margin for potential decline in equipment performance and the possibility of inadequate maintenance, both of which may be likely after repeated use under actual work conditions. The DustControl vacuum provided slightly less than the minimum flow rate described by Collingwood and Heitbrink for a 4.5-inch blade and the peak flow rate fell with use.

The duration of vacuum bag use and mass of dust collected were recorded and are presented in **Table A2 of the Appendix**. The vacuum bags were changed and weighed after each trial utilizing the LEV system. A total of five bags were used to complete the five rounds of grinding. The DustControl vacuum captured 45 pounds of dust over 83 minutes of grinding for an average rate of dust collection of 0.54 pounds per minute. The rate of dust collection ranged from 0.47 to 0.63 pounds per minute. Based on these measurements, **approximately 130 pounds of dust would likely be captured after just 4 hours of continuous grinding**.

The rate of grinding a combination of vertical and horizontal joints while using the LEV system ranged from 2.3 to 3.3 feet per minute. The rate of grinding vertical and horizontal joints without the use of the LEV system ranged from 2.6 to 3.4 feet per minute. The rate of grinding vertical and horizontal joints without the LEV system and with the stock blade guard in place ranged from 4.7 to 5.1 feet per minute. It's important to note that: 1) the operator had limited experience using dust control systems and cut rates appeared to improve slightly over the 2-day period he used the tested equipment; and 2) the upper range of cut rates with the dust control system overlapped with the lowest cut rate with the original guard and without the LEV system in place indicating no statistical difference between cut rates. Given that grinding rates with and without use of this LEV system are only available for one operator and he had limited experience with the LEV system, these reported cut rates are in no way intended to represent the impact use of this LEV system is likely to have on productivity rates overall.

VI. Discussion

The objective of these trials was to evaluate the effectiveness of a tuckpointing LEV system for controlling respirable silica while grinding out mortar joints. The Dust Director shroud with the DustControl 2900c vacuum reduced respirable silica concentrations when grinding with the Bosch grinder by approximately 99 percent. Despite being considered effective by our test criteria (greater than 50% reduction), it still resulted in task TWA exposures that exceeded the NIOSH REL of 0.05 mg/m³ by 1.8 times. Depending on how much time is spent grinding over the course of a work day and on exposures while performing other tasks, the 8-hour TWA exposures may or may not exceed the REL with this system. Use of this system by workers with experience and training in proficient use will likely improve dust capture performance. Exposure reduction is greatly influenced by correct use of this system which includes grinding from right to left, making sure the shroud is held flush against the wall and that the tool travels at a pace that doesn't exceed the ability of the system to capture dust as it's generated. Deviation from any of these measures produces visible dust clouds which were observed during trials.

VII. Conclusions

With a **99 percent reduction in respirable silica exposure**, the **Dust Director shroud and DustControl 2900c vacuum with a Bosch Model 1775E grinder** was effective in reducing silica exposures based on our criteria. Use of the tested dust control system may be effective in reducing silica exposure on the job to less than the NIOSH REL if used in combination with administrative controls such as work scheduling to reduce cutting times as needed. Training on correct use of the tested system is also essential. Personal air monitoring is necessary to verify control effectiveness on actual job sites and under "real-world" conditions. However, these results clearly demonstrate the availability of viable and effective engineering controls for tuckpointing operations associated with elevated silica exposure.

VIII. References

American Conference of Governmental Industrial Hygienists. Threshold Limit Values for Chemical Substances (TLV®-CS). [2013]. ACGIH, Cincinnati.

Bergdahl I.A., Toren K., Eriksson K., et al. [2004]. Increased mortality in COPD among construction workers exposed to inorganic dust. *European Respiratory Journal*, 23: 402–06.

Blanc P.D. & Torén K. [2007]. Occupation in chronic obstructive pulmonary disease and chronic bronchitis: an update [State of the Art Series. Occupational lung disease in high-and low-income countries, Edited by M. Chan-Yeung. Number 2 in the series]. *The International Journal of Tuberculosis and Lung Disease*, 11(3), 251-257.

Collingwood S. & Heitbrink W.A. [2007] 'Field Evaluation of an Engineering Control for Respirable Crystalline Silica Exposures During Mortar Removal'. *Journal of Occupational and Environmental Hygiene*, 4:11, 875 – 887.

DHHS (NIOSH) Publication No. 2002-129
April 2002 <http://www.cdc.gov/niosh/pdfs/02-129.pdf>

Echt A., Sieber W.K., Lefkowitz D., Meeker J., Susi P., Cardwell B., Heitbrink, W.A. In-depth survey of dust control technology for cutting concrete block and tuckpointing brick at The International Masonry Institute Bordentown Training Center, Bordentown, NJ. Cincinnati, OH: U.S. Department of Health and Human Services, Centers for Disease Control and Prevention, National Institute for Occupational Safety and Health, Report.

Heitbrink W., Bennett J. [2006]. A numerical and experimental investigation of crystalline silica exposure control during tuck pointing. *Journal of Occupational and Environmental Hygiene*, Vol. 3, pp 366-378.

Lyons et al, [2007]. A breathless builder. *Breathe*, Vol. 3, no. 4, pp 386-390.

Mastrangelo G., Tartari M., Fedeli U., Fadda E., Saia B. [2003]. Ascertaining the risk of chronic obstructive pulmonary disease in relation to occupation using a case-control design. *Occupational Medicine*, 53: 165–172.

Meeker J., Cooper M., Lefrowitz D., Susi P. [2009]. Engineering control technologies to reduce occupational silica exposures in masonry cutting and tuckpointing. *Public Health Reports, Supplement 1*, Vol. 124, June.

Meeker J, Flynn M, Susi P, Cardwell, B [2004]. Performance evaluation of a masonry concrete vacuum. Unpublished Report.

Miller F. W., Alfredsson L., Costenbader K. H., Kamen D. L., Nelson L. M., Norris J. M., & De Roos A. J. [2012]. Epidemiology of environmental exposures and human autoimmune diseases: findings from a National Institute of Environmental Health Sciences Expert Panel workshop. *Journal of autoimmunity*. No. EPHB 282-13; 2007. <http://www.cdc.gov/niosh/surveyreports/pdfs/ECTB-282-13.pdf>.

Occupational Safety and Health Administration U.S Department of Labor. Controlling Silica Exposures in Construction. [2009]. OSHA 3362-05.

Rappaport SM, Goldberg M, Susi P, Herrick RF [2003]. Excessive exposure to silica in the U.S. construction industry. *Annals of Occupational Hygiene*, Vol. 47, pp. 111-122.

IX. Appendices

Table A1. Flow Rates Calculated From Static Pressure Measurements

Measurement Conditions	n	Mean	Flow Rate (cfm)*	
			Median	Range
Before filter cleaning	5	80	81	78-81
After filter cleaning following manufacturer directions	9	89	90	84-93

* Static pressure was measured in millibars and converted to inches of water gauge. Flow rates were calculated using the formula $Q = C_e (A) 4005 \sqrt{SP}$ where: Q = flow rate in cubic feet per minute (cfm), C_e = coefficient of entry, A = area of the duct where static pressure measurements were taken in square feet, and SP = static pressure in inches of water gauge.

Table A2. Rate of Dust Collection

Tool/Control	Collection Period (min.)	Dust Collection Rate (lb/min.)
	8	0.50
	11	0.61
Bosch grinder/Dust Director shroud & DustControl 2900c vacuum	8	0.50
	8	0.47
	10	0.63
	Average	0.54