

CHAPTER 1

Identifying Asbestos

Learning Objectives

During this lesson, you will learn...

- ① What asbestos is.
- ② That asbestos can be dangerous.
- ③ When asbestos is dangerous.
- ④ How asbestos gets in the air.
- ⑤ Where you may find asbestos.
- ⑥ How asbestos is identified.
- ⑦ About the different kinds of asbestos fibers.

TIME: 2 hr including :15 min break at the end of the session

INCLUDES: Description of asbestos as a mineral; its ability to remain airborne (a dangerous quality); its fiber size; reasons for asbestos use in the past; definition of the term “friable,” identification of asbestos on the job or in the home; types of asbestos; how to protect yourself; an overview of the requirements of the work and protections required within each of the four classes of working with or around asbestos (*Training Fact Sheet*); *Recognizing Asbestos Activity*; *Discussion Questions Activity*; and referencing *Key Facts*

METHODS: Question & Answer (Q&A); Lecturette; Small Group Activity (SGA)

MATERIALS: *EPA Model Asbestos Worker Training Manual (AWM)*, Chapter 1, pp. 1 - 16; **Recognizing Asbestos Activity**, pp. 1 - 2; optional **Discussion Questions**, p. 10; video - **Asbestos Awareness: Are You At Risk?** 23 min, Coastal; slides – some trainers may have slides they wish to use to supplement the video or use in the place of the video – the video is the preferred CPWR choice; see Chapter 8 for *Glossary* (pp. 328 - 341), *Acronyms* (p. 342), and *Summary of OSHA Asbestos Standard 29CFR1926.1101* (pp. 343 - 363)



Choice or combination of: white board/chalk board/flip chart, overhead projector, video player, screen; **AWM**; white board markers and cleaner, chalk and eraser, flip chart pad and markers, overhead transparencies (OHTs), markers, and spare projection bulb; PowerPoint (PPT) or similar program, computer, projector (slide and/or LCD), spare bulbs, and connecting cords; batteries for remotes/laser pointers; and extension cords (GFCI preferred); **optional:** masking tape, duct tape, three-prong electrical adapters, and Leatherman tool or equivalent ... **Note:** avoid confusion among the various types of markers (overhead, white board, and flip chart) and do not write on the projection screen



TIME	METHOD	MATERIALS
:2	Outline learning objectives	Verbal or use of audio/visual teaching aid (i.e., OHT, flip chart, or PPT; screen)
:2	Provide overview of topics and teaching methods for the lesson	Verbal or use of audio/visual teaching aid (i.e., OHT, flip chart, or PPT; screen)

TIME	METHOD	MATERIALS
:8	<p>Ask for volunteers to read the skit, <i>Recognizing Asbestos</i>, and then discuss ...</p> <p style="text-align: center;">SKIT DISCUSSION GUIDE Questions & Possible Answers</p> <p>Q: <u>What do you see happening?</u> What are Will and Chris arguing about?</p> <p>A: “Will wants Chris to tear out the tiles” or “Chris wants to know if the tiles have asbestos in them.”</p> <p>Q: <u>What is really happening here?</u></p> <p>A: “Chris doesn’t want to do what Will is telling him or her to do,” “Chris is being insubordinate,” “Chris is being a wimp,” “Will is asking Chris to work with tiles without finding out if they have asbestos in them,” “Will is telling Chris to do hazardous work without protection,” “Will is being unreasonable,” “Will won’t listen to Chris because she’s a woman.”</p> <p>Q: <u>How is this similar to OUR situation?</u> Do you know anybody who was told to work with building material without knowing if the contained asbestos?</p> <p>A: “A friend of mine was told to rip out floor tiles. Didn’t find out till the next next week that there was asbestos in them,” “When I worked as a custodian, we were told to use a</p>	<p>AWM pages 1-2; Q&A with choice of and/or combination of teaching aids (OHTs, flip charts, white board, or PPT; screen); markers; laser pointer</p> <p>← Note: These questions actually preclude the questions in the AWM on page 2. They are more like triggers.</p> 

TIME	METHOD	MATERIALS
	<p>chemical floor stripper but they wouldn't tell us what was in it...I don't think the supervisor even knew."</p> <p>Q: <u>Why is this a problem?</u> Why do you think Will wanted to tear out the tiles before setting up? Why do you think Chris went along with Will?</p> <p>A: "He's behind schedule," "He wants to save money," He really doesn't know what he is doing," "The owner told him to," "Chris is afraid of getting fired," "She probably thought it wasn't worth the hassle to argue," "Chris figured that Will knew more than she did."</p> <p>Q: <u>What can we do about the problem?</u> or How can you tell if something has asbestos in it? or How can Will and Chris find out where the asbestos is in the building? or What could Chris have done about the tiles? or How could Chris have gotten the information she wanted without getting Will angry – without risking getting fired or disciplined?</p> <p>A: At this point, the instructor may try to draw out of the group some of the important information on identifying asbestos.</p>	<p>← NOTE: This is the first question in this lesson plan that actually points to questions on page 2 on the AWM.</p> <p style="text-align: right;">↔</p>

TIME	METHOD	MATERIALS
:30	Introduce video, play it, and summarize it at the end, making connections to the earlier skit and the fact that the tape is a visual summary of several key aspects of the course and the way they should work	Coastal VHS 23 min video: <i>Asbestos Awareness: Are You at Risk?</i> Video player & monitor/LCD projector
:60	Identify and teach these key topics: ① What is Asbestos? ② When is Asbestos Dangerous? ③ How much Asbestos is in the air? ④ If Asbestos is so dangerous, then why is there so much of it? ⑤ Friable/Non-friable Asbestos ... ⑥ RACM ... ⑦ Identifying Asbestos ... ⑧ Are there different kinds of Asbestos? ⑨ Protecting yourself ...	AWM pages 2 – 10; slides optional if you have some; lecturette, Q&A, and discussion with choice of and/or combination of teaching aids (OHTs, flip charts, white board, or PPT; screen); markers; laser pointer; masking tape
:10	Use <i>Discussion Questions</i> as a summary tool (close-ended questions) and as device to connect or expand on information learned in this learning session ... <p style="text-align: center;">DISCUSSION GUIDE Questions & Possible Answers</p> <p>Q: <u>Is Asbestos dangerous if it gets on your clothes?</u></p>	AWM page 10; Q&A and discussion with choice of and/or combination of teaching aids (OHTs, flip charts, white board, or PPT; screen); markers; laser pointer

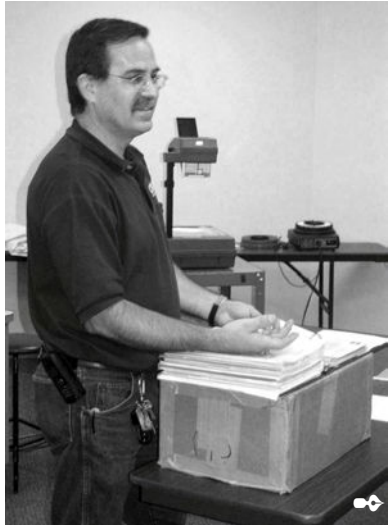

TIME	METHOD	MATERIALS
	<p>A: Asbestos may be an <u>indirect</u> hazard if it gets on clothes. Asbestos will not enter the body through the skin; however, if it is shaken loose from clothes, it can get in the air and can be inhaled. Asbestos is primary a hazard when inhaled. Researchers believe that many cases of family exposure to asbestos came from contaminated work clothes that were shaken out and washed at home. Therefore, it is important for workers to wear protective clothing and to decontaminate whenever they leave the work area.</p> <p>Q. <u>Sometimes air ducts are insulated with Asbestos. Why is this so bad?</u></p> <p>A: Some air ducts are insulated with sprayed-on asbestos or with a papery asbestos containing covering. Some vibration dampers in ducts also contain asbestos. The insulation may be on the inside or on the outside of the ducts. These materials were used to keep the air in the ducts hot or cold, depending on the season. They were also used to lessen vibration where ducts meet.</p> <p>Air ducts carry on throughout buildings. Asbestos is a very light,</p>	

TIME	METHOD	MATERIALS
	<p>small, fiber. It floats in the air and travels wherever air goes. Air flowing through the ducts can easily pull fibers into the air. The system then spreads fibers everywhere in the building.</p> <p>Q: <u>Is asbestos-containing floor tile non-friable? Is this always true?</u></p> <p>A: Asbestos-containing floor tile is usually considered non-friable. It is usually a hard material, and the fibers are usually bound in by a matrix (often vinyl). However, any material can become friable if it is damaged. Floor tile which has been damaged by water, for example, may be chipping, crumbling, or flaking. Floor tile can become friable if maintenance workers drill into it, sand it, or even buff it with harsh abrasives. Floor tile can also become friable if it is removed improperly. Breaking, chipping, blasting, or sanding the tile can release fibers into the air. Tiles should be removed in one piece. A few blasting machines are equipped with HEPA-filtered local exhaust and can be used safely for removing asbestos-containing tiles or mastic.</p> <p>Q. <u>You can't tell whether or not a product contains asbestos by just</u></p>	

TIME	METHOD	MATERIALS
	<p><u>looking at it. Why does this make asbestos more dangerous than other workplace hazards?</u></p> <p>A: Many workplace hazards have some warning properties, i.e., the body can detect the hazard, such as fiberglass irritating the skin, nose, and throat; xylene has a strong chemical smell; heat is felt by the skin; and vehicles make noise. With many hazards, workers know that they are exposed, sometimes long before the hazard can cause much harm. Workers can remove themselves from the hazard or take steps to control it or protect themselves before it harms them.</p> <p>With Asbestos, workers do not even know that they are being exposed. The body cannot detect Asbestos. Workers do not know they need to protect themselves from Asbestos, or even keep it out of the air. This is why it is so important for building owners to identify all Asbestos in and to insist on proper work practices and protective equipment whenever Asbestos is removed. This is also why personal air sampling is so important to workers. It tells workers how much Asbestos their work methods release and how much they are</p>	<p style="text-align: right;">↔</p>

TIME	METHOD	MATERIALS
	<p>exposed to.</p> <p>Q: <u>Why is it harder to work safely with amosite Asbestos than with other kinds of Asbestos?</u></p> <p>A: Amosite and Crocidolite do not soak up water very well. Wetting chrysotile asbestos with amended water keeps most fibers out of the air. Since all respirators leak to some extent, it is very important to keep asbestos out of the air as much as possible. Since amosite will not accept most amended water, removal encapsulants (gluey paints) are usually used. However, removal encapsulants do not work well with amended water. More fibers are released. Local exhaust ventilation (holding a HEPA vacuum next to the work to pull out of the air as soon as it is produced) is recommended. Misting the air and promptly bagging asbestos become even more important when working with amosite asbestos.</p>	
:05	<p>Use Identifying Asbestos Key Facts as a summary tool as device to connect to knowledge gained in this learning session. Refer to Training Fact Sheet as a detailed course reference.</p>	<p>AWM page 11; lecturette; AWM page 12; lecturette</p>

TIME	METHOD	MATERIALS
:02	Summarize session's objectives to refresh the participants about the learning goals achieved during the previous 1:45	Lecturette with choice of and/or combination of teaching aids (OHTs, flip charts, white board, or PPT; screen); markers; laser pointer

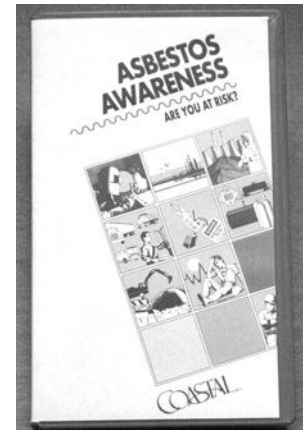

CHAPTER 2

Asbestos Diseases & Medical Exams

Learning Objectives

In Part 1, you will learn...

- ① About the diseases caused by asbestos.
- ② How asbestos gets into your body.
- ③ When asbestos is dangerous.
- ④ How much asbestos can make you sick.
- ⑤ How long it takes you to get sick from asbestos.
- ⑥ How your respiratory (breathing) system works.
- ⑦ The connections between asbestos, smoking, and disease.

In Part 2, you will learn...

- ① What happens during a medical exam.
- ② Why you need a medical exam.
- ③ When to have a medical exam.
- ④ About the medical records your employer has to keep.

TIME: 1:30 min

INCLUDES: Overviews of asbestos-related diseases including asbestosis, mesothelioma, lung cancer, and digestive system-related cancers; concepts of dose-related and

latency period; relationship between smoking and asbestos-related diseases; **Part 1: Asbestos Diseases ... Activity; Discussion Questions Activity;** and *Asbestos Diseases Exercise*; **Part 2: Medical Exams ... Activity and Discussion Questions Activity** and referencing *Key Facts*

METHODS: Q&A; Lecturette; SGA

MATERIALS: Chapter 2 pp. 19 - 46 (*AWM*); **Asbestos Diseases ...Activity**, pp. 19 - 20; optional **Discussion Questions**, p. 35; **Asbestos Diseases Exercise**, p. 36; slides: Tray 1-1 thru 19 or PPT *01 Health Effects of Asbestos Exposure* (see Chapter 12 for slide script: HE 1-19); **Medical Exams ... Activity**, pp. 37 - 38; optional **Discussion Questions**, p. 46; slides Tray 1-21 thru 26 or PPT *02 Medical Surveillance* (see Chapter 12 for slide script: MS 1-6); refer to Chapter 10 pp. 13 - 40 for additional information on asbestosis, cancer, mesothelioma, recent promising chemotherapy efforts, facts regarding smoking and asbestos exposure, and a resource list; and see Chapter 8 for *Glossary* (pp. 328 - 341), *Acronyms* (p. 342), and *Summary of OSHA Asbestos Standard 29CFR1926.1101* (pp. 343 - 363)

Choice or combination of: white board/chalk board/flip chart, overhead projector, video player, screen; **AWM**; white board markers and cleaner, chalk and eraser, flip chart pad and markers, overhead transparencies (OHTs), markers, and spare projection bulb; PowerPoint (PPT) or similar program, computer, projector (slide and/or LCD), spare bulbs, and connecting cords; batteries for remotes/laser pointers; and extension cords (GFCI preferred); **optional:** masking tape, duct tape, three-prong electrical adapters, and Leatherman tool or equivalent ... **Note:** avoid confusion among the various types of markers (overhead, white board, and flip chart) and do not write on the projection screen



TIME	METHOD	MATERIALS
:3	Outline learning objectives	Verbal or use of audio/visual teaching aid (i.e., OHT, flip chart, or PPT; screen)
:2	Provide overview of topics and teaching methods for the lesson	Verbal or use of audio/visual teaching aid (i.e., OHT, flip chart, or PPT; screen)
:8	<p>Ask for volunteers to read the skit, <i>Asbestos Diseases</i>, and then discuss ..</p> <p style="text-align: center;">SKIT DISCUSSION GUIDE Questions & Possible Answers</p> <p>Q: <u>Do you agree or disagree with the following statements. Why or why not?</u></p> <p>A: Wide open discussion or a small group activity. SGA = break the class into small groups of 3-4 students. Ask each person to write his or her own answer next to each question on page 20 without discussing it with anyone else in the group. Then, have each student tell the other group members which answers he or she chose and why. Have the members of each group discuss their individual answers and try to come to a consensus on each question. When each group has</p>	<p>AWM pages 19-20; Q&A (or SGA) with choice of and/or combination of teaching aids (OHTs, flip charts, white board, or PPT; screen); markers; laser pointer</p> <p>The purpose of this activity is to allow students to discuss these subjects with each other and to ➡</p>

TIME	METHOD	MATERIALS
	<p>completed this last task, have all the groups report out what their group decisions are. Also have the reporters report any disagreements on a question.</p> <p>Q: <u>Who would you rather work with, Jesse or Pat?</u></p> <p>A: Pat. "S/he's got a realistic attitude and gets work done," Jesse. "If s/he's careful about waste bags, s/he's probably careful about other things to," Pat. "In my company, if one worker is too slow, we all catch grief."</p> <p>Q: <u>Do you think Jesse decided to help Pat sweep up without a suit and respirator? Why or Why not?</u></p> <p>A: "Yes. Jesse knows that if s/he doesn't help Pat out, Pat won't help him/her in the future," "Yes, It's better to go along and just try to worry about the things that you can control directly," "No, Jesse probably just decided to let Pat sweep up alone. If Pat wants to get poisoned, that's fine," or "No, Pat probably changed his/her mind when s/he saw that Jesse was taking the asbestos seriously."</p> <p>Q: <u>What could Jesse say or do to get Pat to be more careful?</u></p> <p>A: "Nothing, you really can't change people," "Jesse could say, 'Listen, if you want to poison yourself, go ahead. But don't poison me,'" or "Jesse could tell Pat that s/he might</p>	<p>practice the type of group decision-making that they may need to use on the job to abate hazards.</p> <p style="text-align: right;">↔</p>

TIME	METHOD	MATERIALS
	be poisoning his/her own kid if s/he is not careful.”	
:20	<p>Show slides and use as triggers for open-ended questions and close-ended knowledge-specifics that can be found in the Chapter 2; Part 1. Topics to be covered include:</p> <ul style="list-style-type: none"> ① Asbestosis ② Lung Cancer ③ Mesothelioma ④ Other cancers, i.e., digestive tract ⑤ Dose-related ⑥ Latency Period ⑦ How Your Lungs Work <ul style="list-style-type: none"> ➢ Air Exchange ➢ Alveoli ➢ Pleura ⑧ Your Body’s Defenses against Asbestos <ul style="list-style-type: none"> ➢ Mucus ➢ Cilia ➢ White Blood Cells (macrophages) ⑨ Smoking and Asbestos-related Diseases 	<p>Slide Tray 1-1 thru 19 or PPT 01 <i>Health Effects of Asbestos Exposure</i> (see Chapter 12 for slide script: HE 1-19); slide or LCD projector, screen, remote and laser pointer; AWM pages 21 – 33; lecturette, Q&A, and discussion with choice of and/or combination of teaching aids (OHTs, flip charts, white board, or PPT; screen); markers; laser pointer; masking tape</p>
:5	Review Asbestos Diseases Key Facts	<p>AWM page 34; Verbal or use of audio/visual teaching aid (i.e., OHT, flip chart, or PPT; screen)</p>

TIME	METHOD	MATERIALS
	<p>OPTIONAL: Use <i>Discussion Questions</i> as a summary tool (close-ended questions) and as a device to connect or expand on information learned in Part 1</p> <p style="text-align: center;">DISCUSSION GUIDE Questions & Possible Answers</p> <p>Q: <u>Why is it important to know about the health hazards of asbestos?</u></p> <p>A: Since you cannot see, hear, feel, taste, or smell asbestos since the fiber does not irritate us at all. The only warning that you have is the knowledge and understanding of the diseases asbestos causes.</p> <p>Q: <u>When is asbestos most dangerous?</u></p> <p>A: Asbestos is most dangerous when it is in the air. Asbestos fibers enter the body when you breathe or swallow. Asbestos-related diseases may follow years later.</p> <p>Q: <u>Is there a safe level of asbestos exposure?</u></p> <p>A: There is no amount of asbestos that has been proven to be safe. Mesothelioma is not dose-related and the more exposure you receive, the greater the likelihood and severity of asbestosis and asbestos-related cancers.</p>	<p>AWM page 35; Q&A and discussion with choice of and/or combination of teaching aids (OHTs, flip charts, white board, or PPT; screen); markers; laser pointer</p> <p style="text-align: right;">•↔</p>



TIME	METHOD	MATERIALS
	<p>Q: <u>How do we know that asbestos causes diseases that can kill?</u> A: Asbestos is the only known cause for the diseases of asbestosis and mesothelioma. The historical study of the death certificates of 18,000 union asbestos workers in the USA and Canada by Dr. Selikoff of Mt. Sinai Hospital , NY provided the proof.</p>	
:07	<p>SGA = break the class back into their small groups of 3-4 students and assign each group one of the questions from the <i>Asbestos Diseases Exercise</i>. Give them only two minutes to come up with the answer. Have then give the answer to the class as you read the question.</p> <p>✓ End of Chapter 2, Part 1</p>	<p>AWM; Asbestos Diseases Exercise, w/answers on page 36; Q&A and discussion with choice of and/or combination of teaching aids (OHTs, flip charts, white board, or PPT; screen); markers; laser pointer</p>
:01	<p>Remind the learners of the objectives for Part 2: Medical Exams from page 19</p>	<p>Verbal or use of audio/visual teaching aid (i.e., OHT, flip chart, or PPT; screen)</p>
:08	<p>Ask for volunteers to read the skit, <i>Medical Exam</i>, and then discuss ...</p> <p>SKIT DISCUSSION GUIDE Questions & Possible Answers</p>	<p>AWM pages 37-38; Q&A (or SGA) with choice of and/or combination of teaching aids ⇄</p>

TIME	METHOD	MATERIALS
	<p>Q: <u>Why doesn't Lee want to get a check-up?</u></p> <p>A: "Lee's just being strong-willed," "Lee is afraid of losing the job," "Lee doesn't want to find out if s/he is sick. If asbestos diseases take years to kill you, what good it is it to know? Lee will only spend a lot of time worrying."</p> <p>Q: <u>Do you think Lee would really lose his/her job if the doctor found an asbestos-related disease, or is that just an excuse?</u></p> <p>A: "I've seen a lot of people lose their job because they failed a physical," "If you're sick, you need money to pay doctor bills. How can you do that if you lose your job?" "We had a company doctor examine everybody on the job. A few weeks later, a lot of people got laid off because they 'couldn't keep up with the work.' I think the company was just trying to get rid of sick people to save on health benefits," "If Lee works for a big company, s/he probably won't lose the job because they reassign him/her to a different job. But if s/he works for a small contractor, its over."</p> <p>Q: <u>If Lee doesn't get a check-up and then gets sick later, do you think s/he will be able to get Workers' Compensation?</u></p>	<p>(OHTs, flip charts, white board, or PPT; screen); markers; laser pointer</p> <p style="text-align: right;">↔</p>

TIME	METHOD	MATERIALS
	<p>A: “It’s always a hard fight to get Workers’ Compensation. But Lee’s chances will be better if s/he has some health record.” “It will be better for Lee if s/he doesn’t have any records. That way the company can’t use the records against him/her if there is a claim filed,” “It doesn’t matter. It takes so long to get Workers’ Compensation that, even if the Workers’ Compensation Board decides in Lee’s favor, Lee will die of asbestosis before getting a check!”</p> <p>Q: <u>If you were Lee’s family, what would you want Lee to do?</u></p> <p>A: “The family needs Lee to keep on working. Maybe they could get him/her to see a private doctor without telling the contractor. That way she/he could keep working but also be looking for a new job,” “Lee’s family might want him to get a regular physical. They’d probably prefer to do without some luxuries than see Lee die early.”</p> <p>Q: <u>If you were Lee’s employer, what could you do to make Lee less afraid of losing his/her job?</u></p> <p>A: “I would send workers to an outside clinic for exams rather than send them to the company doctor,”</p>	<p style="text-align: right;">•◊</p>

TIME	METHOD	MATERIALS
	<p>“I would guarantee in writing that any worker who flunked the exam would be give a job with the same pay that doesn’t require them to work with asbestos,” “I would have a meeting and explain to everybody what the exams are for.”</p>	
:29	<p>Show slides and use as triggers for open-ended questions and knowledge-specifics that can be found in the Chapter 2; Part 2. Topics to be covered include:</p> <ol style="list-style-type: none"> ① Medical Exams/Medical Surveillance ② Baseline Exams ③ When a medical exam required ④ Required parts of a medical exam <ul style="list-style-type: none"> ➤ Work History ➤ General Physical Exam ➤ Pulmonary Function Test ⑤ Recommended Parts of a Medical Exam <ul style="list-style-type: none"> ➤ Chest X-ray ➤ EKG (electrocardiogram) ➤ Sputum Cytology ➤ Hemocult Slide ⑥ Medical Exam Results ⑦ Medical Exam Records 	<p>Slide Tray 1-21 thru 26 or PPT <i>02 Medical Surveillance</i> (see Chapter 12 for slide script: MS 21-26); slide or LCD projector, screen, remote and laser pointer; AWM pages 38 – 44; lecturette, Q&A, and discussion with choice of and/or combination of teaching aids (OHTs, flip charts, white board, or PPT; screen); markers; laser pointer; masking tape</p>
:05	Review Medical Exams Key Facts	<p>AWM page 45; Verbal or use of audio/visual teaching aid (i.e.,</p>

TIME	METHOD	MATERIALS
		OHT, flip chart, or PPT; screen)
	<p><u>OPTIONAL:</u> Use <i>Discussion Questions</i> as a summary tool (close-ended questions) and as a device to connect or expand on information learned in Part 2</p> <p style="text-align: center;">DISCUSSION GUIDE Questions & Answers</p> <p>Q: <u>What good is medical surveillance?</u> A: Medical surveillance provides a way to find out early if you have an asbestos-related disease. It provides documentation for Workers' Compensation and legal claims.</p> <p>Q: <u>Why is it important to find asbestos diseases early?</u> A: If you find that you have asbestosis, you would:</p> <ul style="list-style-type: none"> ➤ stop your exposure to asbestos ➤ stop smoking ➤ get flu shots early to stop respiratory infections ➤ treat respiratory infections with antibiotics immediately <p>If you find you have mesothelioma and it is diagnosed at a lower stage, you can use your time to put your personal affairs in order.</p>	<p>AWM page 46; Q&A and discussion with choice of and/or combination of teaching aids (OHTs, flip charts, white board, or PPT; screen); markers; laser pointer</p> 

TIME	METHOD	MATERIALS
	<p>A: Medical Questionnaire (Appendix D; 9 - 12 pages long) with work history, exposure history, medical history, family medical history, and your smoking history; A General Physical Exam, including lungs, heart, and digestive system; and a Pulmonary Function Test, or breathing test. This test may lead to an x-ray.</p> <p>Q: <u>What is a baseline exam?</u> A: The baseline exam is your first required asbestos medical exam and it documents how healthy you are before you are exposed to asbestos as an abatement work. It also determines your ability to wear a respirator.</p> <p>Q: <u>How long must an employer keep medical records?</u> A: Thirty years (30) plus duration of employment.</p> <p>Q: <u>Why keep your own copies of medical records?</u> A: You have a legal right to your medical records. Your contractor may be out of business or claim you didn't work there.</p> <p>Q: <u>What do I do when I am no longer working with asbestos and do not get yearly medical surveillance?</u></p>	  

TIME	METHOD	MATERIALS
	A: Get an annual exam with rectal exam.	
:02	Summarize session's objectives to refresh the participants about the learning goals achieved during the previous 1:30	Lecturette with choice of and/or combination of teaching aids (OHTs, flip charts, white board, or PPT; screen); markers; laser pointer

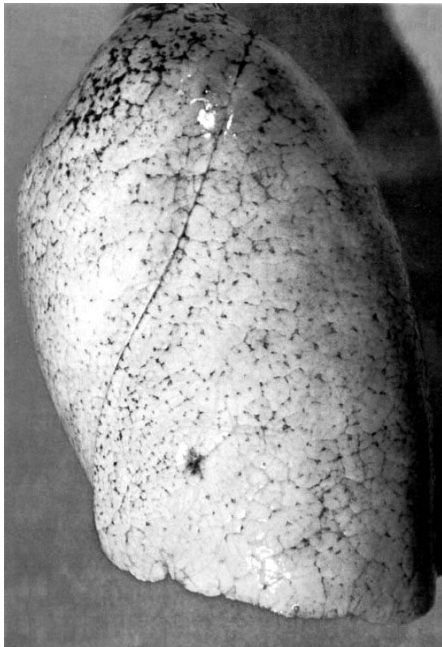

Healthy Lung



Cancerous Lung

CHAPTER 3

Laws & Regulations

Learning Objectives

After this lesson, you will learn about...

- ① Regulations, and how they are enforced.
- ② The difference between federal and state asbestos laws.
- ③ The laws that protect you on the job.
- ④ The laws that protect the environment on the job.

TIME: 1:15 min

INCLUDES: Description of federal laws and regulations or standards, the Environmental Protection Agency (EPA), Asbestos Hazard Emergency Act (AHERA), Asbestos School Hazard Abatement Re-authorization Act (ASHARA), National Emission Standards for Hazardous Air Pollutants (NESHAP), Occupational Safety & Health Administration (OSHA: 29CFR1926.1101; 29CFR1910.134; 29CFR 1926.59), state asbestos laws; *OSHA Exercise*; *Discussion Questions Activity*; and referencing *Key Facts*

METHODS: Q&A; Lecturette; SGA

MATERIALS: Chapter 3, pp. 47 - 192 (*AWM*); *OSHA Exercise*, pp. 188 - 191; optional *Discussion Questions*, p. 192; see Chapter 8 for *Glossary* (pp. 328 - 341), *Acronyms*

(p. 342), and *Summary of OSHA Asbestos Standard 29CFR1926.1101* (pp. 343 - 363); and Chapter 9 for applicable state law(s)



Choice or combination of: white board/chalk board/flip chart, overhead projector, video player, screen; **AWM;** white board markers and cleaner, chalk and eraser, flip chart pad and markers, overhead transparencies (OHTs), markers, and spare projection bulb; PowerPoint (PPT) or similar program, computer, projector (slide and/or LCD), spare bulbs, and connecting cords; batteries for remotes/laser pointers; and extension cords (GFCI preferred); **optional:** masking tape, duct tape, three-prong electrical adapters, and Leatherman tool or equivalent ... **Note:** avoid confusion among the various types of markers (overhead, white board, and flip chart) and do not write on the projection screen

TIME	METHOD	MATERIALS
:02	Outline learning objectives	Verbal or use of audio/visual teaching aid (i.e., OHT, flip chart, or PPT; screen)
:02	Provide overview of topics and teaching methods for the lesson	Verbal or use of audio/visual teaching aid (i.e., OHT, flip chart, or PPT; screen)
:45	Identify and teach these key topics: ① EPA ② AHERA	AWM pages 48 – 73; lecturette, Q&A, and discussion with

TIME	METHOD	MATERIALS
	<ul style="list-style-type: none"> ③ ASHARA ④ NESHAP ⑤ OSHA <ul style="list-style-type: none"> > 29CFR1926.1101 > 29CFR1926.134 > 29CFR1926.59 ⑥ State law ⑦ How to read a standard... 	choice of and/or combination of teaching aids (OHTs, flip charts, white board, or PPT; screen); markers; laser pointer; masking tape
:05	Review Laws Key Facts	AWM page 187; Verbal or use of audio/visual teaching aid (i.e., OHT, flip chart, or PPT; screen)
:19	SGA = break the class back into their small groups of 3-4 students and assign each group three of the questions from the <i>OSHA Exercise</i> . Give them only five minutes to come up with the answers. Have them give the answers to the class as you read the question.	AWM; OSHA Exercise, w/ answers on pages 188 - 191; Q&A and discussion with choice of and/ or combination of teaching aids (OHTs, flip charts, white board, or PPT; screen); markers; laser pointer
	OPTIONAL: Use <i>Discussion Questions</i> as a summary tool (close-ended questions) and as a device to connect or expand on information learned in Chapters 3 & 8	AWM page 192; Q&A and discussion with choice of and/or

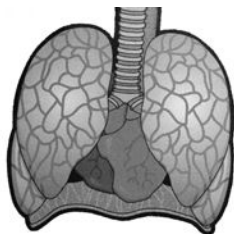
TIME	METHOD	MATERIALS
	<p style="text-align: center;">DISCUSSION GUIDE Questions & Possible Answers</p> <p>Q: <u>Why do the federal government and states both have laws about asbestos?</u></p> <p>A: (1) Some states wish to give its workers more protection than the federal government does. (2) These states may also want to enforce its own OSHA laws and exclude the federal government. (3) Finally, the states many wish to pass its own licensing law so that it can better track who is doing what asbestos work – and where.</p> <p>Q: <u>Is the legal limit for asbestos totally safe?</u></p> <p>A: No. When OSHA issued is PEL of 0.1 f/cc - TWA = 8, it estimated the risk of contracting an asbestos-related disease when working at the PEL for 45 years without a respirator as: cancer risk = 6.6 per 1,000 workers; asbestosis risk = 5.0 per 1,000 workers; OSHA's PELs are negotiated; OSHA's PELs must be technologically and/or economically feasible</p> <p>Q: <u>Why do you have to keep asbestos out of the air when you already have to wear a respirator and a suit?</u></p>	<p>combination of teaching aids (OHTs, flip charts, white board, or PPT; screen); markers; laser pointer</p> <div style="text-align: center;">  </div> <p style="text-align: right;">•→</p>

TIME	METHOD	MATERIALS
	<p>A: OSHA recognizes that a respirator can only remove some of the asbestos from the worker’s breathing zone. Every respirator leaks. Engineering controls and work practices remove a lot of the asbestos from the worker’s breathing air, which means less to get past the respirator. The hierarchy of controls is:</p> <ol style="list-style-type: none"> 1. Substitute a less hazardous material or process; 2. Use engineering controls; 3. Mechanize the process; 4. Enclose the operation or the worker; 5. Isolate the process; 6. Use ventilation; 7. Local exhaust ventilation; 8. General or dilution ventilation; 9. Use work practices; 10. Use good housekeeping; 11. Use administrative controls; or 12. Use personal protective equipment (PPE). <p>Q: <u>Some laws are good, but they are not enforced. What can anyone do to get the laws enforced better?</u></p> <p>A: Lobby for greater enforcement budgets.</p> <p>Q: <u>Some laws are not good. What can anyone do to get better laws passed?</u></p> <p>A: Write letters to office holders, vote, and join organizations that lobby for them.</p>	

TIME	METHOD	MATERIALS
:02	Summarize session's objectives to refresh the participants about the learning goals achieved during the previous 1:15	Lecturette with choice of and/or combination of teaching aids (OHTs, flip charts, white board, or PPT; screen); markers; laser pointer

Type osha.gov in your favorite web browser for the OSHA web page. Then, click on "standards" under "Laws & Regulations" in the blue column on the right. Next, click on the grey button on the right titled "construction." Scroll almost all the way to the bottom until you reach "Subpart Z – Toxic and Hazardous Substances." The second entry under this subpart is 1926.1101 – Asbestos. CLICK. Hyperlink in blue takes you to interpretations of the affected paragraph.

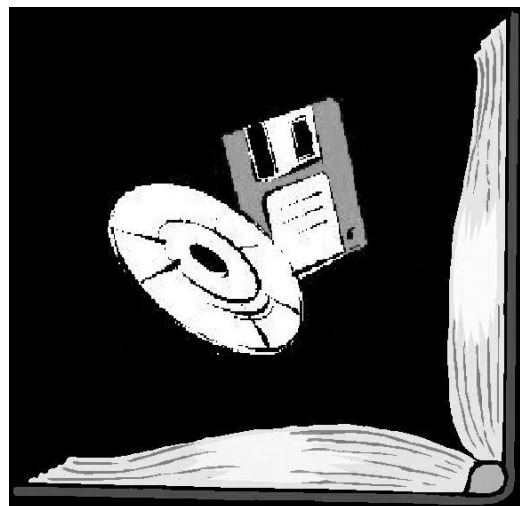

CHAPTER 4

Control Methods Setup & Removal

Learning Objectives

After this lesson, you will learn...

- ① How asbestos can be controlled.
- ② About the kind of asbestos abatement work you may do.

TIME: :45 including :15 min break at the end of the session

INCLUDES: Five asbestos control methods: (1) encapsulation; (2) enclosure; (3) repair; (4) removal; and (5) operations & maintenance program (O&M); *Discussion Questions Activity* and referencing *Key Facts*

METHODS: Q&A; Lecturette

MATERIALS: Chapter 4, pp. 194 - 197; optional *Discussion Questions*, p. 199; see Chapter 8 for *Glossary* (pp. 328 - 341) and *Acronyms* (p. 342)

Choice or combination of: white board/chalk board/flip chart, overhead projector, video player, screen; **AWM**; white board markers and cleaner, chalk and eraser, flip chart pad and markers, overhead transparencies (OHTs),



markers, and spare projection bulb; PowerPoint (PPT) or similar program, computer, projector (slide and/or LCD), spare bulbs, and connecting cords; batteries for remotes/laser pointers; and extension cords (GFCI preferred); **optional:** masking tape, duct tape, three-prong electrical adapters, and Leatherman tool or equivalent ... **Note:** avoid confusion among the various types of markers (overhead, white board, and flip chart) and do not write on the projection screen

TIME	METHOD	MATERIALS
:02	Outline learning objectives	Verbal or use of audio/visual teaching aid (i.e., OHT, flip chart, or PPT; screen)
:01	Provide overview of topics and teaching methods for the lesson	Verbal or use of audio/visual teaching aid (i.e., OHT, flip chart, or PPT; screen)
:20	Identify and teach these key topics: <ul style="list-style-type: none"> ① Pre-bid walk through; ② Encapsulation; ③ Enclosure; ④ Repair; ⑤ Removal; and ⑥ Operations & Maintenance. 	AWM pages 194 – 197; Q&A, and discussion with choice of and/or combination of teaching aids (OHTs, flip charts, white board, or PPT; screen); markers; laser pointer; masking tape

TIME	METHOD	MATERIALS
:05	Review Control Methods Key Facts	AWM p. 198; Verbal or use of audio/visual teaching aid (i.e., OHT, flip chart, or PPT; screen)
	<p><u>OPTIONAL:</u> Use <i>Discussion Questions</i> as a summary tool (close-ended questions) and as a device to connect or expand on information learned in <i>Pre-work Activities and Control Methods</i></p> <p style="text-align: center;">DISCUSSION GUIDE Questions & Answers</p> <p>Q: <u>What kind of material do you think would not be good to encapsulate?</u></p> <p>A: Determining which control method to use in any particular case depends upon several factors, i.e., what type of material is it (pipe covering, sprayed-on TSI); where the material is located (boiler room, hallway), and whether renovation or retro-fit work is planned for the area in the near future. Examples of situations where encapsulation would not be useful include: material which is friable; sprayed-on material which is delaminating from the substrate; material which is readily accessible to the public; material which is in an area soon to undergo renovation; or</p>	<p>AWM p. 199; Q&A and discussion with choice of and/or combination of teaching aids (OHTs, flip charts, white board, or PPT; screen); markers; laser pointer</p> <p style="text-align: right;">◆</p>

TIME	METHOD	MATERIALS
	<p>material subject to on-going water damage.</p> <p>Q: <u>Can you see a situation in which more than one control method might be used in an area?</u></p> <p>A: Such situation fall into two categories: (1) a single material might be selectively removed in some areas and encapsulated in the rest of the areas, i.e., material removed could be in areas where it is accessible (entrances of a domed auditorium) and the rest encapsulated; and (2) a single project might include removal of one type of material and the repair of another.</p>	
:02	Summarize session's objectives to refresh the participants about the learning goals achieved during the previous :30	Lecturette with choice of and/or combination of teaching aids (OHTs, flip charts, white board, or PPT; screen); markers; laser pointer

**Lesson Plan #5:
 Worksite Preparation/
 Setup/Decontamination Unit
 begins on next page →**

CHAPTER 4

Worksite Preparation, Setup and Decontamination Unit

Learning Objectives

In this lesson, you will learn...

- ① How to keep asbestos out of the air.
- ② About wearing a respirator and disposable suit.
- ③ What an asbestos job looks like.
- ④ How to clean the work room.
- ⑤ How to set up the workroom.

TIME: 2 hr

INCLUDES: Keeping asbestos wet; containing the work area; filtering the air; using negative air pressure; Class 1 and Class 2 setup; *Setup... Activity*; (2) *Discussion Questions*; *Setup and Decon Exercise*; and referencing *Key Facts*

METHODS: Q&A; Lecturette, SGA

MATERIALS: Chapter 4, pp. 200 - 218, 225 - 226, and 233 (*AWM*); *Setup... Activity*, p. 200, optional *Discussion Questions*, p. 205, optional *Discussion Questions*, p. 218, and *Setup and Decon Exercise*, p. 233; slides: Slide Tray 1-27 thru 60 or PPT *03 Worksite Prep & Decon* (see Chapter 12 for slide script: P&D 1-34); and see Chapter 8 for *Glossary* (pp. 328 - 341) and *Acronyms* (p. 342)





Choice or combination of: white board/chalk board/flip chart, overhead projector, video player, screen; **AWM;** white board markers and cleaner, chalk and eraser, flip chart pad and markers, overhead transparencies (OHTs), markers, and spare projection bulb; PowerPoint (PPT) or similar program, computer, projector (slide and/or LCD), spare bulbs, and connecting cords; batteries for remotes/laser pointers; and extension cords (GFCI preferred); **optional:** masking tape, duct tape, three-prong electrical adapters, and Leatherman tool or equivalent ... **Note:** avoid confusion among the various types of markers (overhead, white board, and flip chart) and do not write on the projection screen

TIME	METHOD	MATERIALS
:02	Outline learning objectives	Verbal or use of audio/visual teaching aid (i.e., OHT, flip chart, or PPT; screen)
:01	Provide overview of topics and teaching methods for the lesson	Verbal or use of audio/visual teaching aid (i.e., OHT, flip chart, or PPT; screen)
:12	<p>Ask for volunteers to read the skit, Setup ..., and then discuss ...</p> <p style="text-align: center;">SKIT DISCUSSION GUIDE Questions & Possible Answers</p> <p>Q: <u>Do you agree or disagree with the following? Why or why not?</u></p>	<p>AWM page 200; Q&A with choice of and/or combination of teaching aids (OHTs, flip charts, white board, or PPT; screen); markers; laser pointer</p> <p style="text-align: right;">↔</p>

TIME	METHOD	MATERIALS
	<p>A: Wide open discussion or a small group activity. SGA = break the class into small groups of 3-4 students. Ask each person to write his or her own answer next to each question on page 200 without discussing it with anyone else in the group. Then, have each student tell the other group members which answers he or she chose and why. Have the members of each group discuss their individual answers and try to come to a consensus on each question. When each group has completed this last task, have all the groups report out what their group decisions are. Also have the reporters report any disagreements on a question.</p> <p>Q: <u>Why is Tom in such a hurry?</u></p> <p>A: “The supervisor is riding him to work faster,” “He’s afraid he’ll lose his job,” “His supervisor doesn’t care about his workers’ health; s/he just wants the job done quick and cheap,” “The contractor probably bid the job too low and is now trying to make up the losses by having the workers do a quick and dirty job,” “Tom isn’t thinking about his future and his health, he’s just concerned wit how much money he can make today,” or “He’s probably a lot younger than Carlos.”</p>	<p>The purpose of this activity is to allow students to discuss these subjects with each other and to practice the type of group decision-making that they may need to use on the job to abate hazards.</p> <p style="text-align: right;">↔</p>

TIME	METHOD	MATERIALS
	<p>Q: <u>What could Carlos do to convince Tom to wear his respirator and suit?</u></p> <p>A: “Nothing, you really can’t change people,” “Carlos could explain to Tom what diseases asbestos can cause,” Carlos could tell Tom that he might be poisoning his own kids if he’s not careful,” “Carlos could tell Tom to stop being such a ‘brown-nose.’ After all, if one worker is willing to go without suiting up, the supervisor will expect everybody else to do the same.”</p> <p>Q: <u>What could the supervisor do to make it easier for Tom to wear his respirator and suit?</u></p> <p>A: “S/he could schedule setup for cooler parts of the day and have them do other jobs that don’t require respirators when it’s really hot,” S/he could assign a third person to help setup, that way everybody could work at an easier pace,” or “S/he could threaten to discipline Tom if s/he catches him without his suit or respirator.”</p>	
:40	<p>Show slides and use as triggers for open-ended questions and close-ended knowledge-specifics that can be found in the Chapter 4: Setup - <i>Keeping Asbestos Out of the Air</i>. Topics to be covered include:</p> <ol style="list-style-type: none"> ① Keep the asbestos wet; ② Contain the work area; 	<p>Slide Tray 1-27 thru 60 or PPT 03 <i>Worksite Prep & Decon</i> (see Chapter 12 for slide script: P&D 1-34); slide or LCD projector, screen,</p>

TIME	METHOD	MATERIALS
	<p>③ Filter the air; and ④ Use negative air pressure.</p> <p>Show participants where they can find the session’s material in the AWM.</p> <p>(option: show slides #61-66 in this Lesson or in Lesson #6; setup vs engineering controls)</p> 	<p>remote and laser pointer; AWM pages 201 – 204; lecturette, Q&A, and discussion with choice of and/or combination of teaching aids (OHTs, flip charts, white board, or PPT; screen); markers; laser pointer; masking tape</p>
	<p><u>OPTIONAL:</u> Use <i>Discussion Questions</i> as a summary tool (close-ended questions) and as device to connect or expand on information learned in this session</p> <p style="text-align: center;">DISCUSSION GUIDE Questions & Possible Answers</p> <p>Q: <u>Why not spread asbestos fibers around us and lower the concentration in the air?</u></p> <p>A: There is no safe level of asbestos exposure. Even the smallest amount of asbestos could be dangerous, so it all must be controlled. This is done by (1) enclosing the work area and (2) filtering all the air in the room and the air that leaves the room. This is done with negative air machines, HEPA</p>	<p>AWM page 205; Q&A and discussion with choice of and/or combination of teaching aids (OHTs, flip charts, white board, or PPT; screen); markers; laser pointer</p> <p style="text-align: right;">↔</p>

TIME	METHOD	MATERIALS
	<p>vacuums, and tools with attached HEPA filters.</p> <p>Q: <u>Why won't fibers leak out if there is a negative air machine set up?</u></p> <p>A: Without a negative air machine, air is free to move in and out of the work room. It can travel through holes and gaps in the poly, as well as the decon as workers enter and exit. However, the negative air machine is more powerful than the air currents in the room. The fan pulls in "makeup air" into the regulated area through the decon, picking up asbestos fibers along the way. It exhausts the filtered outside the work area while maintaining slightly negative pressure inside.</p> <p>Q: <u>How does surfactant cause water to soak the asbestos material better than plain water?</u></p> <p>A: Surfactant is also known as a wetting agent. A surfactant reduces the surface tension of water. Water droplets treated with a surfactant are able to "soak" in ACM than stay on its surface as droplets.</p>	 <p>5 gallons of surfactant</p>
:43	<p>Setup Continued: Identify and teach these key topics:</p> <ul style="list-style-type: none"> ① Class 1 Setup <ul style="list-style-type: none"> ➤ Put up warning Signs & barrier tape 	<p>AWM pages 206-217; lecturette, Q&A, and discussion with</p>

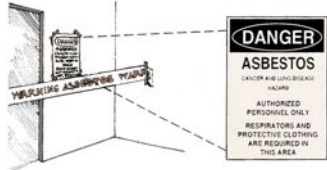
TIME	METHOD	MATERIALS
	<ul style="list-style-type: none"> ➤ Shut off the ventilation system ➤ Shut off the electrical system ➤ Bring in extension cords ➤ Build the decontamination unit ➤ Cover all windows and openings to the room ➤ Clean everything in the room ➤ Throw out what you can't clean ➤ Take out anything you can move ➤ Wrap anything you can't move in poly ➤ Hook up and test the negative air machine ➤ Put poly on the floor ➤ Put poly on the walls ➤ Bring scaffolds and tools into the room ➤ Position the decontamination unit <ul style="list-style-type: none"> ➤ Test the negative air pressure <p>② Class 2 Setup</p> <ul style="list-style-type: none"> ➤ Put warning signs and barrier tape ➤ Shut off the ventilation system ➤ Shut off the electrical system ➤ Bring in extension cords ➤ Cover all openings to the room with poly ➤ Clean everything in the room ➤ Throw out what you can't clean ➤ Wrap anything you can't move in poly ➤ Bring scaffolds and tools into the room ➤ Put poly on the floor ➤ See exceptions on the top of page 217 	<p>choice of and/or combination of teaching aids (OHTs, flip charts, white board, or PPT; screen); markers; laser pointer; masking tape</p>  <p>The diagram illustrates a Class 2 asbestos abatement setup. It shows a room with a decontamination unit (a box with a fan) positioned near an opening. A barrier tape is strung across the opening, and a warning sign is posted on the wall. The sign reads: 'DANGER ASBESTOS CANCER AND LUNG DISEASE HAZARD AUTHORIZED PERSONNEL ONLY RESPIRATORS AND PROTECTIVE CLOTHING ARE REQUIRED IN THIS AREA'. Dashed lines indicate the placement of the barrier tape and the sign.</p>

TIME	METHOD	MATERIALS
	<p><u>OPTIONAL:</u> Use <i>Discussion Questions</i> as a summary tool (close-ended questions) and as device to connect or expand on information learned in this session</p> <p style="text-align: center;">DISCUSSION GUIDE Questions & Possible Answers</p> <p>Q: <u>Why shouldn't the electricity be turned off at the wall switches?</u></p> <p>A: It is easy to remove tape and turn on equipment at wall switches. Also, some electric wiring may not be de-energized by switches. Workers could easily be shocked, and workers have died on abatement sites in this kind of accident. All circuit breakers should be tripped and all fuses should be pulled. The box should be tagged and locked with a lock that has only one key. If there are two shifts, each shift (or worker) should have its own lock and key. (See 29CFR1910.147)</p> <p>Q: <u>Why are there two layers of poly put on the floor?</u></p> <p>A: In general, two layers of 6mil polyethylene sheet plastic (visqueen) are put on the floor of the work room (regulated area). Putting on two layers ensures that if there is a leak, it will not leak directly onto the floor.</p> <p>Strength is critical on the floor where</p>	<p>AWM page 218; Q&A and discussion with choice of and/or combination of teaching aids (OHTs, flip charts, white board, or PPT; screen); markers; laser pointer</p> <p>✂ ----- This activity can be done now, after the Key Facts Review, or, of course, not at all if time doesn't permit.</p> <p style="text-align: right;">◆</p>

TIME	METHOD	MATERIALS
	<p>The poly must stand up to people walking and equipment rolling across it. Clean-up is made easier with two layers of poly. Heavier poly can be put on the floor to handle heavier loads while lighter, 4mil poly may be used on the walls (lightens the drag and helps keep poly from falling down). Sometimes a third layer of poly is put on the floor and is taken up each night, enhancing cleanup. On a floor tile removal, critical barriers only are put up. No poly is on the walls or ceiling. Floor tiles are removed whole, or intact, so as to minimize the release of fiber-containing dust. The critical barriers are necessary in order to sustain negative pressure and ensure airflow throughout the work room.</p> <p>Q: <u>Some state laws say that you have to put plywood on the floor if you leave carpets on the floor when you remove asbestos. Why is this done?</u></p> <p>A: Sheathing is necessary because carpet is a soft surface and heavy equipment can easily rip sheet plastic on this surface. However, plywood increases the chance that asbestos and water will leak through and damage and/or contaminate carpet. It is best to remove the carpet and dispose of it as asbestos waste.</p>	 <p style="text-align: right;">↔</p>

TIME	METHOD	MATERIALS
	<p>Q: <u>You have to protect yourself from asbestos when you set up. What other dangers do you have to think about when you are setting up?</u></p> <p>A: Workers should be aware of these hazards when setting up:</p> <ul style="list-style-type: none"> ➤ heat ➤ fire ➤ electricity ➤ chemicals ➤ confined spaces ➤ slips, trips, and falls ➤ scaffolds and ladders <p>.. See Chapter 7 for more information</p> <p>Q: <u>You are about to start a project where the material being removed is on the ceiling of a computer room and the computers cannot be shut down. How could you do the preparation of the work area in this case?</u></p> <p>A: A containment within a containment could be set up. The computers would be enveloped in sheet poly, probably on a frame. The computer containment could be big enough for someone to enter or not, depending on the specific needs of the job. This containment would be positively pressurized so that air leakage would be out of the containment and into the work area. The inner containment would be cleaned and treated as a</p>	

TIME	METHOD	MATERIALS
	<p>critical barrier.</p> <p>Q: <u>You are working on an asbestos removal job in a multi-storied building. Several elevators run through the middle of the floor. What kinds of problems does this pose? What could you do to solve the problem?</u></p> <p>A: Designate one elevator for to-and-from travel of abatement workers. Critical barrier the other elevators and have maintenance lock them out from the abatements floors, which start at the top. Plan an emergency route out in case elevators cannot be used. Critical barrier off stairs except the one designated for emergency.</p>	
:15	<p>SGA = break the class back into their small groups of 4-5 students and assign each group one of the questions from the <i>Setup and Decon Exercise</i>. Give them only five minutes to come up with the answers. Have them give the answers to the class as you read the question.</p>	<p>AWM; Setup and Decon Exercise, w/ answers on page 233; Q&A and discussion with choice of and/ or combination of teaching aids (OHTs, flip charts, white board, or PPT; screen); markers; laser pointer</p>

TIME	METHOD	MATERIALS
:05	Review Keeping Asbestos Out of the Air Key Facts and Setup Key Facts	AWM page 204 and 217 ; Verbal or use of audio/visual teaching aid (i.e., OHT, flip chart, or PPT; screen)
:02	Summarize Setup session's objectives to refresh the participants about the learning goals achieved during the previous 2 hours	Lecturette with choice of and/or combination of teaching aids (OHTs, flip charts, white board, or PPT; screen); markers; laser pointer

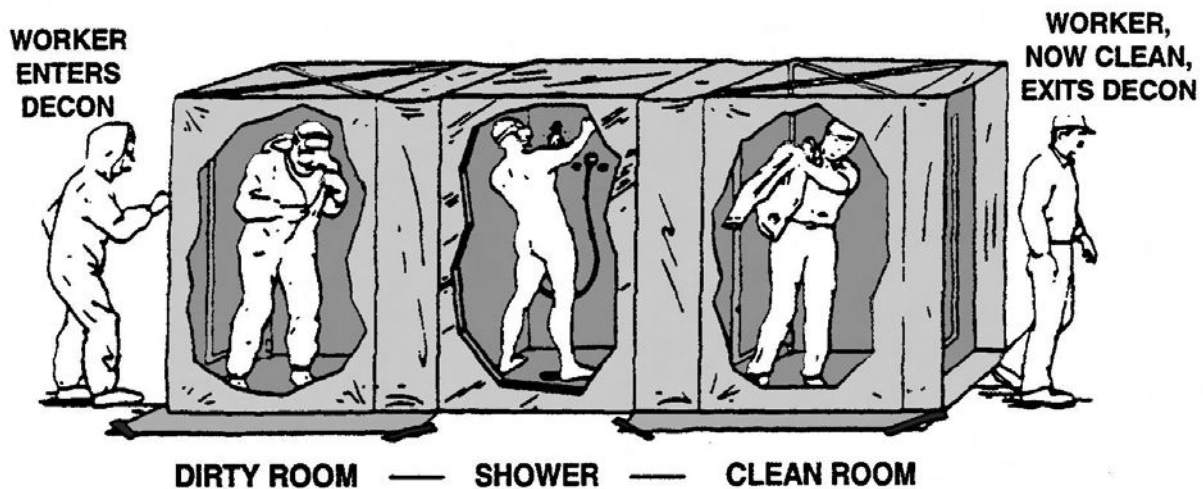

Lesson Plan #6:
Work Practices and Engineering Controls
 begins on next page →

CHAPTER 4

Work Practices & Engineering Controls

Learning Objectives

During this lesson, you will learn ...

- ① How to enter a work room.
- ② How to take asbestos off ceilings, walls, and pipes.
- ③ How to keep asbestos out of the air.
- ④ How to bag asbestos waste.
- ⑤ How to exit the work room.
- ⑥ How your employer measures asbestos in the air.
- ⑦ How to work with Class I & II asbestos.
- ⑧ How to remove asbestos from pipes.
- ⑨ How to use a mini-enclosure and a glovebag.
- ⑩ About Class III asbestos work.

TIME: 2:45 min including :15 min break at the end of the session

INCLUDES: Class I Removal; Class II Removal; Maintenance-Related Removal – Mini-Enclosures and Glovebags; Competent Person; *Work Methods ... Activity; Discussion Questions (2); Maintenance-related Removal ... Activity; Glove Bag Exercise*; and referencing *Key Facts*

METHODS: Q&A; Lecturette; SG A; Demonstration

MATERIALS: Chapter 4, pp. 219 - 237, except pp. 225 - 226 (**AWM**); **Work Methods ... Activity**, pp. 219 - 220; optional Discussion Questions, p. 234; optional Maintenance-related Removal ... Activity, p. 235; **Glove Bag Exercise**, pp. 244 - 245; optional Discussion Questions, p. 246; slides: Tray 1-67 thru 100 or PPT *04 Removal Techniques* (see Chapter 12 for slide script: RT 1-34); and see Chapter 8 for *Glossary* (pp. 328 - 341), *Acronyms* (p. 342)



Batteries

Choice or combination of: white board/chalk board/flip chart, overhead projector, video player, screen; **AWM**; white board markers and cleaner, chalk and eraser, flip chart pad and markers, overhead transparencies (OHTs), markers, and spare projection bulb; PowerPoint (PPT) or similar program, computer, projector (slide and/or LCD), spare bulbs, and connecting cords; batteries for remotes/laser pointers; and extension cords (GFCI preferred); **optional:** masking tape, duct tape, three-prong electrical adapters, and Leatherman tool or equivalent ... **Note:** avoid confusion among the various types of markers (overhead, white board, and flip chart) and do not write on the projection screen

TIME	METHOD	MATERIALS
:03	Outline learning objectives	Verbal or use of audio/visual teaching aid (i.e., OHT, flip chart, or PPT; screen)
:02	Provide overview of topics and teaching methods for the lesson	Verbal or use of audio/visual teaching aid (i.e., OHT, flip chart, or PPT; screen)

TIME	METHOD	MATERIALS
:15	<p>Ask for volunteers to read the skit, <i>Work Methods</i>, and then discuss ..</p> <p style="text-align: center;">SKIT DISCUSSION GUIDE Questions & Possible Answers</p> <p>Q: <u>Who is right, Ed or Jeff?</u> A: “Jeff. You really need to be able to keep up with the people around you,” “Jeff. If Ed slows Jeff down, they’ll both be in hot water with the supervisor for working too slow, “Ed. You shouldn’t let asbestos lay around on the floor.”</p> <p>Q: <u>Is there anything wrong with leaving asbestos waste on the floor instead of bagging it right away?</u> A: “It’s ok to leave it as long as yo clean it up at the end of the day,” “You should bag as you scrape to keep it from drying out and getting into the air,” “The law says you have to bag it up as you go, but I’ve never been on a job where it was done that way.”</p> <p>Q: <u>Why should you be concerned about stirring up fibers if you are wearing a respirator?</u> A: “if you’re wearing a half-mask, fibers will leak in. But if you’ve got a PAPR, you don’t have to worry. It will protect you,” “As long as you’ve got a respirator on you don’t have to worry about stirring up fibers,” “All</p>	<p>AWM pages 219-220; Q&A (or SGA) with choice of and/or combination of teaching aids (OHTs, flip charts, white board, or PPT; screen); markers; laser pointer</p> <div style="text-align: right;">  </div>

TIME	METHOD	MATERIALS
	<p>respirators leak some. So you have to try to keep fibers out of the air.”</p> <p>Q: <u>Do you agree or disagree with the following statements? Why or Why not?</u></p> <p>A: Wide open discussion or a small group activity. SGA = break the class into small groups of 4-5 students. Ask each person to write his or her own answer next to each question on page 220 without discussing it with anyone else in the group. Then, have each student tell the other group members which answers he or she chose and why. Have the members of each group discuss their individual answers and try to come to a consensus on each question. When each group has completed this last task, have all the groups report out what their group decisions are. Also have the reporters report any disagreements on a question.</p> <p>Q: <u>Why do you think Jeff is in such a hurry?</u></p> <p>A: “If Ed and he are the only ones on the job, they need to work fast to get it all done on time,” “Jeff is careless.”</p> <p>Q: <u>What would the supervisor do to make sure the asbestos is bagged as soon as it is scraped?</u></p> <p>A: “The supervisor could have two workers bag while one scrapes,” “The</p>	<p>The purpose of this activity is to allow students to discuss these subjects with each other and to practice the type of group decision-making that they may need to use on the job to abate hazards.</p> <p style="text-align: right;">↔</p>

TIME	METHOD	MATERIALS
	<p>supervisor could have them scrape the waste directly onto a scaffold to make it easier to bag quickly.”</p>	
<p>2:00</p>	<p>Show slides and use as triggers for open-ended questions and close-ended knowledge-specifics that can be found in the Chapter 4: <i>Class I & Class II Asbestos Removal and Maintenance-related Removal – Mini-enclosures and Glovebags</i>. Topics to be covered include:</p> <ul style="list-style-type: none"> ① Class I Removal <ul style="list-style-type: none"> ➤ Entering the Work Room ➤ Keep the Asbestos Wet ➤ Scraping ➤ Bagging ➤ Special Tools ➤ Clean Up Every Day <ul style="list-style-type: none"> ✓ Demo NAM & HEPA Vac ➤ Competent Person ② Class II Asbestos Removal <ul style="list-style-type: none"> ➤ Removal of Vinyl Asbestos Tile and Sheeting ➤ Removal of Asbestos-Containing Roofing Material ➤ Removal of Asbestos-Containing Siding, Shingles, and Transite Panels ③ Class III (small) Asbestos Jobs <ul style="list-style-type: none"> ➤ Mini-enclosures ➤ Glovebag Removal <ul style="list-style-type: none"> ✓ Glovebag Exercise ➤ Repairing Asbestos <p>Show participants where they can find this session’s material in the AWM.</p>	<p>Slide Tray 1-67 thru 100 or PPT <i>04 Removal Techniques</i> (see Chapter 12 for slide script: RT 27-60); (option: show slides #61-66 from Lesson #5 if not shown there; slide or LCD projector, screen, remote and laser pointer; AWM pages 220 – 242; <u>Demonstrate NAM and HEPA vacuum</u>; <i>Glove Bag Exercise w/answers pages 244-245</i>; lecturette, Q&A, and discussion with choice of and/or combination of teaching aids (OHTs, flip charts, white board, or PPT; screen); markers; laser pointer; masking tape</p>

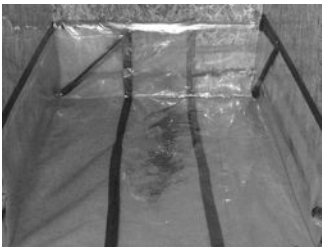
TIME	METHOD	MATERIALS
	<p><u>OPTIONAL:</u> Use <i>Discussion Questions</i> as a summary tool (close-ended questions) and as a device to connect or expand on information learned in <i>Class I & Class II Asbestos Removal</i></p> <p style="text-align: center;">DISCUSSION GUIDE Questions & Answers</p> <p>Q: <u>Why do you put colored chalk under the seams between sheets of poly on the floor?</u></p> <p>A: This is an effective means of telling at the end of the shift whether or not asbestos has leaked under the top layer of floor poly. If the seams leak or an unseen rip or tear has developed, the carpenter's chalk turns dark and may even seem to smear. You then must open up the poly, clean the contamination, and re-seal.</p> <p>Q: <u>Why do you put tape or wood on covered stairways?</u></p> <p>A: If you have to use a decon away from the regulated area (i.e., you are doing a job on the second floor and you have a mobile trailer on the first floor), then you have to build a covered stairway. The wet poly is extremely slippery. Placing tape or wood over the poly makes it less slippery.</p>	<p>AWM page 234; Q&A and discussion with choice of and/or combination of teaching aids (OHTs, flip charts, white board, or PPT; screen); markers; laser pointer</p> 

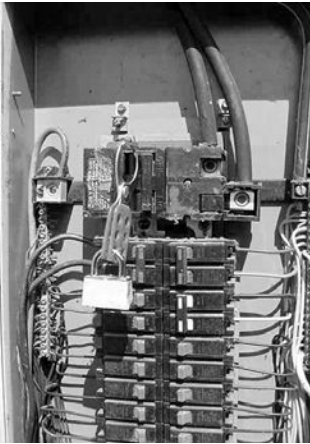
TIME	METHOD	MATERIALS
	<p>Q: <u>There are some jobs where you need to be extra careful. If you know about good work methods, how to use a respirator, and how to understand air sampling results, you can figure out what to do on an unusual job. Here are a few examples which you can use for discussion.</u></p> <p>A: Amosite Asbestos Amosite asbestos does not soak up water, no matter what kind of surfactant is used. Sticky paints called removal encapsulants must be used to keep dust out of the air. HEPA vacuums may be used next to the work to pull fiber containing dust out of the air as it is created. PAPRs may need to be used because of possible higher fiber counts in the air.</p> <p>A: Can't Shut Off the Electricity When and if electricity must remain on, asbestos must be removed dry. Electricity should remain on when someone's life depends on it – in a hospital, public utility, or a vital industry. The best solution is to enclose the electrical circuits – build a temporary box around them so that workers cannot be injured by them. Sticky paints called removal encapsulants may be used to keep dust out of the air; however, if the paints are conductive, they are</p>	

TIME	METHOD	MATERIALS
	<p>dangerous as well. HEPA vacuums may be used next to the work to pull fiber containing dust out of the air as it is created. PAPRs may need to be used because of possible higher fiber counts in the air. The contractor must apply to EPA for permission to work dry. PAPRs may need to be used because of possible higher fiber counts in the air.</p> <p>A: Working Equipment in the Workroom Operating equipment can pose many dangers – mechanical injuries, electrical, and heat or fire. The best solution is to enclose the machine – build a temporary box around it so that workers will not be injured by it; however, the box must always have filtered vents to let air in and heat out.</p> <p>A: Taking Off Asbestos Above a Drop Ceiling 1) At the end of setup, a sample of tiles should be removed to see if any hidden openings or ducts are above. The negative air machine should be on and the tiles should be removed by a worker in a suit and respirator who vacuums of the edge of the tile as s/he lowers it. Any openings (especially air plenums with partial walls below) must be sealed off before work begins.</p>	

TIME	METHOD	MATERIALS
	<p>2) Tiles should be removed carefully and will probably be too contaminated to clean, so they must be thrown out. The negative air machine should be on and the tiles should be removed by a worker in a suit and respirator who vacuums of the edge of the tile or wet it down as s/he lowers them.</p> <p>A: <u>Taking off part of the asbestos in a large room (like taking off half of the ceiling from a warehouse).</u> In this case, a partial barrier has to be built to hang poly on. In some states, this can be a simple 2x4 frame. In other states, a full wall with caulked joints must be built. If this wall must be built up against an asbestos-containing ceiling, it should be anchored to the tops of the walls, not the ACM ceiling. The material on the ceiling should be wetted down if building the wall will disturb it.</p>	
	<p><u>OPTIONAL:</u> Use <i>Discussion Questions</i> as a summary tool (close-ended questions) and as a device to connect or expand on information learned in <i>Class III Asbestos Removal</i></p> <p style="text-align: center;">DISCUSSION GUIDE Questions & Answers</p>	<p>AWM page 246; Q&A and discussion with choice of and/or combination of teaching aids (OHTs, flip charts, white board, or ➡</p>

TIME	METHOD	MATERIALS
	<p>Q: <u>When you use a HEPA vacuum for negative pressure on a mini-enclosure, where do you put it? At the top of the mini-enclosure? At the bottom? In the decon?</u></p> <p>A: Ordinarily, and with one exception, the HEPA vacuum should go at the bottom of the enclosure. Just as in a full containment, the source of negative air should go opposite the source of makeup air – in this case, the joint where the mini-enclosure seals to the ceiling. This way the air in the whole work area is moved to the HEPA vacuum. If there is a change room built into the mini-enclosure, the vacuum should go at the far end of the change room from the mini-enclosure. Workers can check for negative air pressure by watching the curtain between the two rooms. If there is enough pressure, the curtain will be pulled in towards the vacuum.</p> <p>Q: <u>How do you use a mini-enclosure to string cables above a drop ceiling? Do you need an enclosure at both ends? How can you set up negative air pressure?</u></p> <p>A: Dropped ceilings often cover up sprayed-on asbestos above. These spaces are sometimes air plenums (air in the building circulated through</p>	<p>PPT; screen); markers; laser pointer</p> <p style="text-align: right;">↔</p>

TIME	METHOD	MATERIALS
	<p>this open space). For this job, one mini-enclosure should be built at either end of the run. It is difficult to get true negative pressure in this situation. The best solution is to attach a HEPA vacuum hose at the top of each mini-enclosure.</p> <p>Asbestos can be released when the tiles are removed and the cable is pulled. The vast majority of fibers sit in the large area above the ceiling. The conventional approach would be to attach the vacuum at the bottom of the enclosure. But placing a vacuum at the bottom may pull fibers into a space that would otherwise stay relatively clean.</p> <p>Q: <u>What kind of enclosure would you use to take the asbestos off one small boiler in a large basement?</u></p> <p>A: A full containment should be built out of 2x4s and two layers of 6mil poly. While this is a small job, it does not fit the definition of a “small-scale, short-duration” job. The containment does not need to be much bigger than the boiler itself, only large enough to work around.</p>	
:08	Review Removal Key Facts and Maintenance-related Removal Key Facts	AWM pages 232 and 243; Verbal or use of audio/visual

TIME	METHOD	MATERIALS
		teaching aid (i.e., OHT, flip chart, or PPT; screen)
:02	Summarize session's objectives to refresh the participants about the learning goals achieved during the previous 2:30	Lecturette with choice of and/or combination of
		teaching aids (OHTs, flip charts, white board, or PPT; screen); markers; laser pointer

Negative Air Machine Background

Air Flow

Air comes in through the filters on one side and out through top or other side of the machine, depending on design. The air must be filtered first or else the motor becomes contaminated. The motor cannot be cleaned.

Filters

Three types: (starting from the outermost filter) – **primary, secondary** and **HEPA**. The primary filter (also called a gross filter) catches the largest particles. The secondary filter catches smaller particles and is usually more stiff, often in a cardboard case or containing a wire stiffener (also a gross filter). The HEPA filter is often a foot thick and contains zigzag metal pleats in a metal case, sealed with a rubber strip. The HEPA (*High Efficiency Particulate Air*) filter will catch **99.97%** of all particles **0.03 microns** or larger.

Filter Changing

The primary and secondary filters must be changed many times a day. These two filters are not required in the regulations, but they are used because they will save the employer a lot of money. These two filters catch asbestos fibers **before** they can clog up the more expensive HEPA filter.

A HEPA filter's cost starts between \$200 - \$400, each. The primary and secondary filters, also known as **pre-filters**, can simply be removed while the NAM is still running, misted, and disposed of in asbestos waste bags. On the other hand, the HEPA filter must be changed out in a clean room, or in a set up work room before taken in to the regulated area, or in a negatively pressurized decon.

As a rule of thumb, primary filters (or the first pre-filter) should be changed out 2 - 4 times a shift. In a dirty work area, they may be changed as often as once or twice an hour. This filter should be changed when the manometer goes above 1". Secondary filters (or the second pre-filter) should be changed once or twice a day (more often in a dirty work area). This filter is changed when the primary filter has been changed and the manometer is still above 1". HEPA filters should be changed approximately every 700 hour as recorded from the hours of service counter on the NAM.

Is the Air Leaving the Work Area Clean?

If the filters and the gaskets work (and the machine is not turned off), only 0.03% of the asbestos should leak out. Asbestos in the air outside the NAM can be measured using **area air sampling** (see pages 225 - 227).

Control Panel

Lights/Alarms: Warning lights (and eventually shutdown lights and alarms) if installed on the NAM can go off under the three conditions:

Electrical Faults – shorts, insufficient amperage; the machine should be hooked up to a GFCI;

Low Pressure – if the HEPA filter or its gasket breaks or is broken, asbestos can leak around the filter; the pressure difference across

the filter drops too low and the machine should shut itself off; and

High Pressure – if the filters become dirty, too little air will get through the filter and the motor will strain; the pressure difference across the filter goes too high and the machine should shut off.

Manometer: This pressure gauge measures the **resistance** across the filter. The gauge should measure between .5 and 1" of resistance. (Note: This is not the same as -0.02" water pressure across a poly barrier.) If the filter or gasket is torn, resistance will drop. If the filter is loaded with asbestos, the resistance will rise. Filters should be changed (first the primary filter, then if necessary the secondary filter) when the needle goes above 1".

Hours of Service: This counter measures the hours the unit has been in service. The HEPA filter should be changed approximately every 700 hours, as measured on this counter. Changing the filters must be carefully timed and should be done before the job begins. The job must be shut down if the HEPA filter needs to be changed in the middle of a job. (A backup NAM can already be in the regulated area or staged outside waiting to be brought in for a seamless switch.)

When Is the Machine On?

NAMs are to be on 24 hours a day from the time asbestos is disturbed until the clearance sample is passed.

Sizes/Brands

NAMs are available in many different sizes and brands from 500 to 25,000 cubic feet per minute. (NAMs found on lead abatement bridge jobs may be larger.) A 2,000 cfm machine probably puts out only 1,800 cfm.

Number of Machines/Volume of Air

The machine(s) must bring an entire roomful of fresh air into the work area every **15 minutes**. The formula is:

1. Volume of Room (WxDxH) ÷ by 15 = CFMs needed
2. CFMs needed ÷ 2,000 (for a 2,000 cfm machine)
3. Number of NAMs needed

Negative Pressure Glovebags

Two paragraphs downloaded from osha.gov on 06/05/03:

1926.1101(g)(5)(iii)

Negative Pressure Glove Bag Systems. Negative pressure glove bag systems may be used to remove ACM or PACM from piping and

1926.1101(g)(5)(iv)

Negative Pressure Glove Box Systems: Negative pressure glove boxes may be used to remove ACM or PACM from pipe runs with the following specifications and work practices.

Pictured at the right is a hose adapter, pressure control, and rod, and bag seals being used on a glove bag. →

Pictured below is a close-up of the hose adapter and the pressure control/air rod.

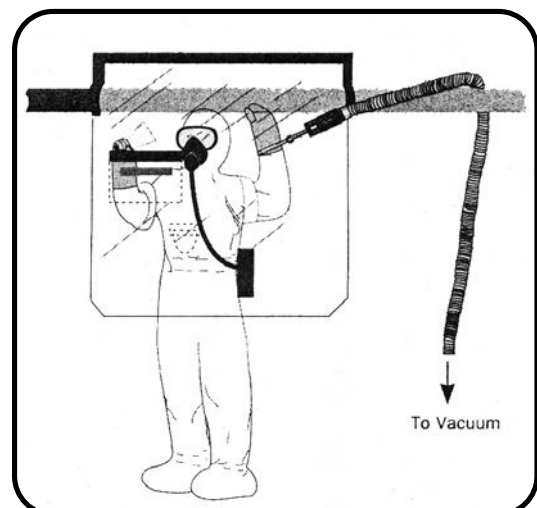
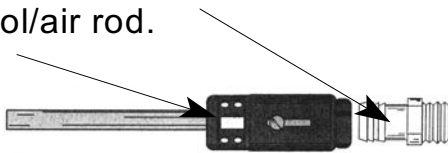

Selected Letters of Interpretation downloaded from osha.gov on 06/05/03:

April 4, 1990

Mr. Rick Howell
Universal Insulation, Inc.
Post Office Box 4243
Birmingham, Alabama 35206

Dear Mr. Howell:

This is in response to your letter of March 7, requesting an official opinion as to whether The Glove Box manufactured by Pro/Control Products, Inc., which you propose to use for the removal of asbestos-containing pipe insulation, meets the intent of the occupational safety and health requirements at [29 CFR 1926.1101(g)(5)(iv)].

The Occupational Safety and Health Administration (OSHA) does not approve or certify equipment or processes for use in the workplace. However, when we are provided with adequate information concerning a control method, we do offer an opinion regarding its effectiveness in achieving compliance with our requirements for employee safety and health. Therefore, this letter is not an approval or a certification of The Glove Box, but is an interpretation of our standards as they apply to the use of this system in United States workplaces.

It appears that the use of your system meets the intent of [29 CFR 1926.1101(g)(5)(iv)] when all other provisions of the asbestos standard are met, such as air monitoring, establishment of a regulated area, designation of a competent person, etc. However, please be aware that the effectiveness of your system can only be determined by the health and safety professional observing it in actual use under specific circumstances.

We appreciate your interest in the safety and health of workers. If you have additional questions, please feel free to contact us again.

Sincerely,

Thomas J. Shepich Director
Directorate of Technical Support

(Correction 12/01/01)

November 17, 1994

Mr. Daniel Fousek
Woodward-Clyde Consultants
30775 Bainbridge Road, Suite 200
Solon, OH 44139

Dear Mr. Fousek:

This is in response to your letter dated August 12, 1994 to Mr. Rob Medlock, the Area Director in the Cleveland Area Office. You requested clarification on the use of negative pressure glovebags for the removal of asbestos-containing materials (ACM) and you asked if there is a maximum amount that can be removed using glovebags.

As you may be aware, on August 10, 1994, the Occupational Safety and Health Administration (OSHA) published in the Federal Register final standards for Occupational Exposure to Asbestos. The new standard includes major revisions that are germane to the issues you have concerning glovebags.

In light of the considerable comment and evidence OSHA received on glovebag effectiveness, the decision was made to allow increased glovebag use for the removal of asbestos containing materials (ACM) and Thermal system Insulation (TSI) without quantity limitation. The term "small--scale, short duration" is no longer used in the standard. In the

Construction standard, CFR 29 1926.1101, OSHA has added four classes of activity which triggers provisions of the standard. The removal of ACM as described by your letter appears to be Class I work although that would need to be evaluated by the competent person. The specific control methods are explained in 1926.1101(g)(5). Each method is a system which consists of tangible material, devices, procedures and practices and an employer must comply with each element. A copy of the standard is provided for your review.

Depending on the class of work being done and the method of compliance chosen, **the employer may use ambient or "regular" glovebags or negative pressure glovebags.** [bold added] Prior to disposal, glovebag shall be collapsed by removing air within the bag by using a HEPA vacuum. Under the new standard, the issue of whether to use low-volume pump or a high-volume pump, is not pertinent.

The methods of compliance described above shall be implemented as soon as possible, but no later than April 10, 1995. [bold added]

We hope this information is responsive to your concerns.

Sincerely,

Ruth McCully, Director
Office of Health Compliance Assistance

May 15, 1997

Robert W. Weeks, Jr., Ph.D.
Director, FSI
Field Sciences Institute
2501 Baylor Drive, SE
Albuquerque, New Mexico 87106

Dear Mr. Weeks:

This is in response to your letter of March 28, addressed to the former Director of the Office of Health Compliance Assistance, Ms. Ruth McCully, concerning glove bag methods for control of exposure to airborne asbestos.

You requested that we clarify 29 CFR 1926.1101(g)(5)(B)(iii). You noted that this regulation states that negative pressure glove bag systems shall attach HEPA vacuum systems or other devices to prevent collapse during removal. You ask if there has been a modification or clarification of this regulation to allow the use of glove bags without attaching a HEPA vacuum system.

Please be advised that the control method given at 29 CFR 1926.1101(g)(5)(ii) is a glove bag procedure that does not require the attachment of a HEPA vacuum system. The regulation you specifically mentioned in your letter, 29 CFR 1926.1101(g)(5)(iii) is a procedure for using a negative pressure glove bag system. OSHA still requires that glove bag systems specifically designed to be used under negative pressure have a HEPA vacuum system attached. However, a glove bag system not designed to be used under a vacuum can be operated without a HEPA vacuum system attached. [bold and underlining added]

We appreciate the opportunity to clarify this matter for you. If you have any additional questions, please call Gail Brinkerhoff at (202) 219-7380.

Sincerely,

Stephen Mallinger, Acting Director
Office of Health Compliance Assistance

Containment Area Pressure Monitor

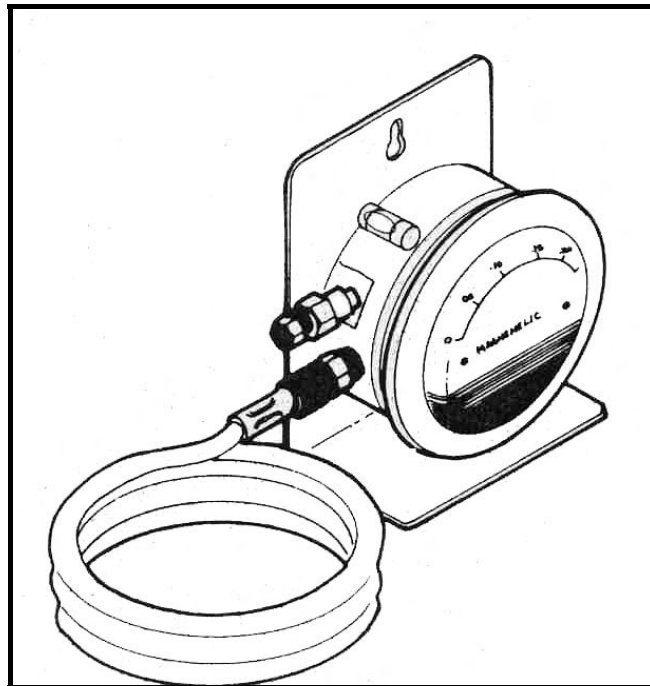

The Containment Area Pressure Monitor provides an assessment of the pressure differential between the inside and outside of an enclosure, to insure the minimum 0.02" difference in water column is maintained.

CHAPTERS 1, 4, and 6

Asbestos Bulk Sampling and Air Monitoring

Learning Objectives

After this lesson, you will be able to...

- ① Recognize that asbestos identification is done by means of a bulk sample analyzed at a lab on a Polarized Light Microscope (PLM).
- ② Recognize that air samples can be taken either with an area sampler or a personal sampling pump and analyzed at a lab using a Phase Contrast Microscope.
- ③ Recognize that a final air sample is called a clearance sample, must be 0.01 ff/cc to pass, and that is tested at a lab using either a PCM or TEM (Transmission Electron Microscope).

TIME: :45 min

INCLUDES: Identifying asbestos; air sampling; testing the air at the end of the job; and referencing *Key Facts*

METHODS: Q&A; Lecturette; Demonstration

MATERIALS: Chapter 1, pp. 6 - 9; Chapter 4, pp. 225 - 227; and Chapter 6, pp 290 - 292 (*AWM*); Personal Sampling Pump with asbestos air sampling cassette and

Rotometer; and see Chapter 8 for *Glossary* (pp. 328 - 341) and *Acronyms* (p. 342)



Teaching Box

Choice or combination of: white board/chalk board/flip chart, overhead projector, video player, screen; **AWM;** white board markers and cleaner, chalk and eraser, flip chart pad and markers, overhead transparencies (OHTs), markers, and spare projection bulb; PowerPoint (PPT) or similar program, computer, projector (slide and/or LCD), spare bulbs, and connecting cords; batteries for remotes/laser pointers; and extension cords (GFCI preferred); **optional:** masking tape, duct tape, three-prong electrical adapters, and Leatherman tool or equivalent ... **Note:** avoid confusion among the various types of markers (overhead, white board, and flip chart) and do not write on the projection screen

TIME	METHOD	MATERIALS
:02	Outline learning objectives	Verbal or use of audio/visual teaching aid (i.e., OHT, flip chart, or PPT; screen)
:01	Provide overview of topics and teaching methods for the lesson	Verbal or use of audio/visual teaching aid (i.e., OHT, flip chart, or PPT; screen)
:12	<i>Identifying Asbestos:</i> Stress the PACM rule of 1980; the only way to tell if a material is asbestos is send a sample to the lab for Polarized Light Microscopy; and apply the ACM percentage rule to	AWM pages 6-9; Q&A with choice of and/or combination of teaching aids (OHTs, flip charts, white

TIME	METHOD	MATERIALS
	the sample report on page 8	board, or PPT; screen); markers; laser pointer
:18	<p><i>Air Sampling:</i> Note that the employer must take air samples every shift from some workers – this is Personal Sampling which should be contrasted with Area Sampling; outside air samples are usually taken to ensure that air from the NAMs are clean and that there aren't any emissions from the decon and waste load out areas; discuss the difference in sampling analysis – these air samples are analyzed using a Phase Contrast Microscope (PLM); have the students evaluate the sample report on page 227; demonstrate the Personal Sampling Pumps, its unique shaped cassette, and its field calibration device</p>	<p>AWM pages 225-227; Q&A with choice of and/or combination of teaching aids (OHTs, flip charts, white board, or PPT; screen); markers; laser pointer; Demonstration of Personal Sampling Pump</p> 
:10	<p><i>Clearance Air Sampling;</i> an abatement work area cannot be declared clean until it has passed an aggressive air clearance sampling with a result of 0.01 f/cc or less; a PCM microscope is used unless it is a school; then, a Transmission Electron Microscope is used (TEM)</p>	<p>AWM pages 290-292; Q&A with choice of and/or combination of teaching aids (OHTs, flip charts, white board, or PPT; screen); markers; laser pointer</p>
:02	Summarize sampling and monitoring session's objectives to refresh the participants about the learning goals achieved during the previous :30 min	Lecturette with choice of teaching aids

Calibration of a Personal Sampling Pump

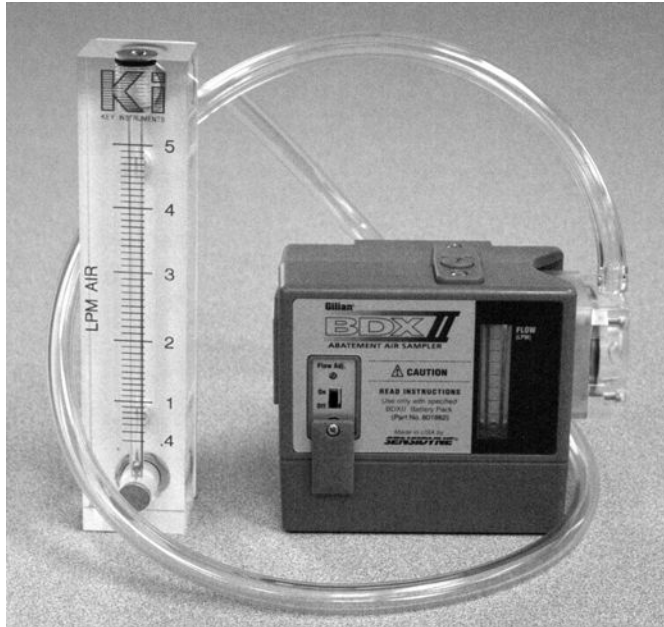

Field Calibration

Factory Calibration

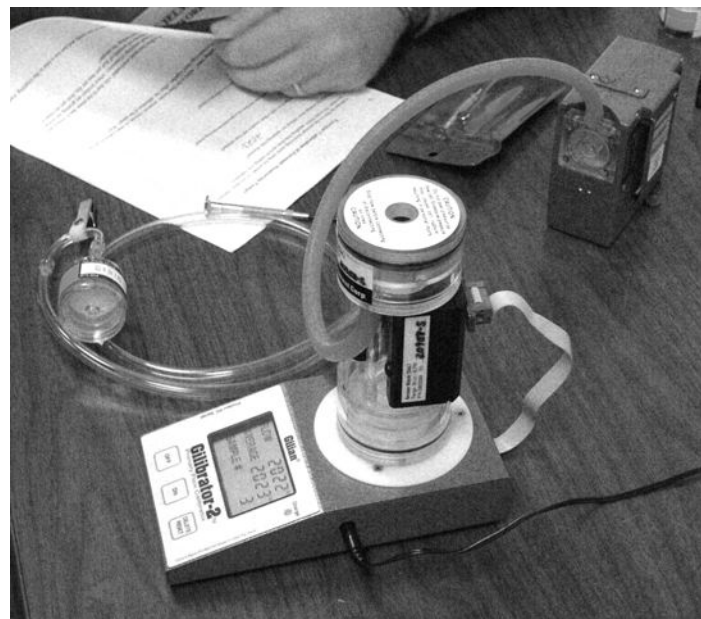

Bulk Sampling Kit

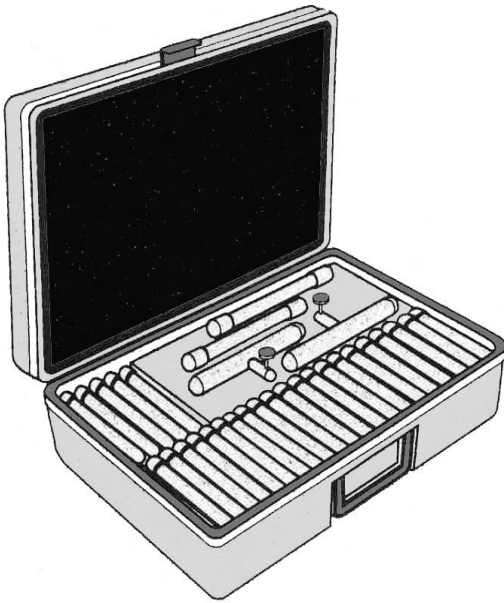

2 handles, 2 plungers, 100 cutter sleeves and 100 clear slim vials with caps. Optional items available: double-length cutters, power drivers, extraction unit, coring arm, and plunger adapter.

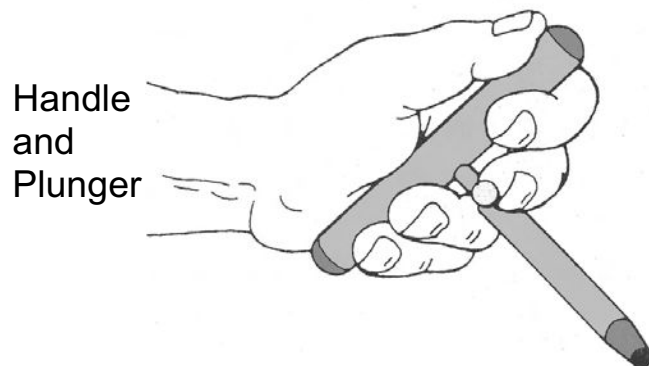

Area Air Sampling Pumps

3 Port Manifold
3 separate
simultaneous
samples can be
taken

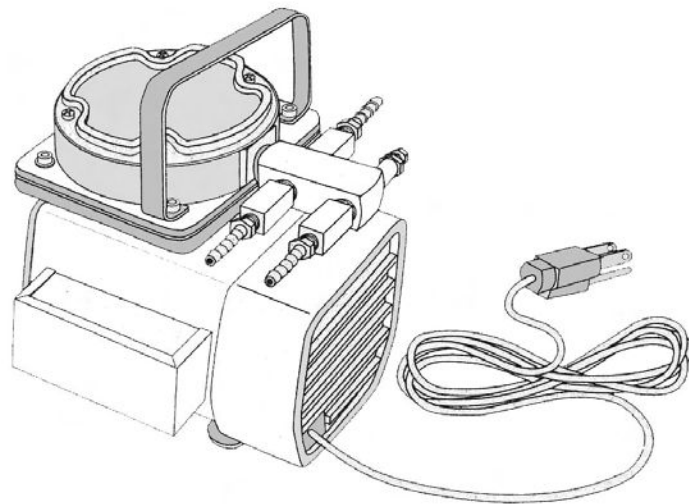

5 Port Manifold; 5 separate simultaneous
samples can be taken

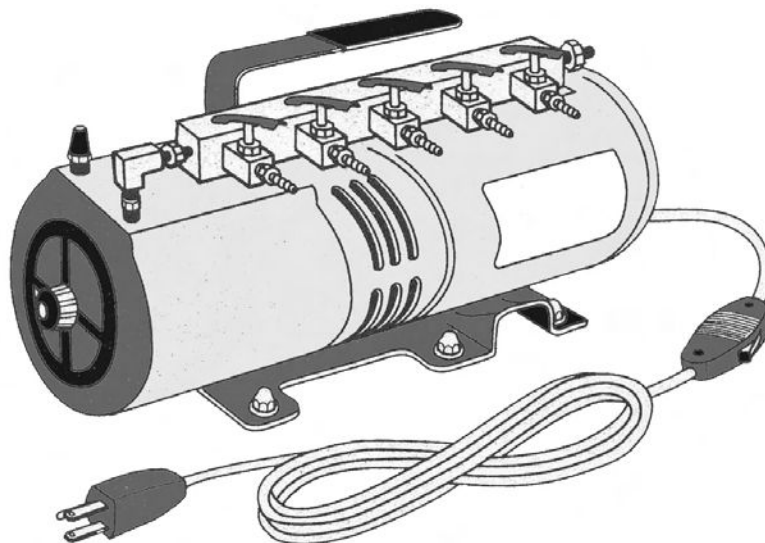

Letter of Interpretation: ERP

April 26, 1994

Ms. Janet Fox
Director, Industrial Hygiene and Safety Services
Occupational Health Department
Consolidated Edison, Company of New York, Inc.
30 Flatbush Avenue
Brooklyn, New York 11217

Dear Ms. Fox:

Thank you for your letter of November 22, 1993 concerning the Occupational Safety and Health Administration's (OSHA) Hazardous Waste Operations and Emergency Response (HAZWOPER) regulation, 29 CFR 1910.120, and Asbestos regulation for construction, [29 CFR 1926.1101]. We apologize for the delay in this reply.

You request clarification on the use of direct reading instruments during the initial response phase to an emergency release of asbestos, and whether the results of such real-time monitoring may be used for the downgrading of the level of personal protective equipment (PPE) in use. You also inquire whether the OSHA Asbestos standard would apply to an emergency release of asbestos.

Elements of both the HAZWOPER and Asbestos standards would apply to any emergency response to an uncontrolled hazardous substance release involving the presence of asbestos. Further, paragraph (a)(2)(I) of 29 CFR 1910.120 states that where HAZWOPER overlaps with another OSHA standard, the provision which is more protective of employee safety and health shall apply.

The monitoring requirements of the Asbestos standard are more protective than those of the HAZWOPER standard. The Asbestos standard requires that determination of employee exposure levels be based upon full shift and 30 minute breathing zone air **samples** of employees with

representative exposures, which are to be evaluated in accordance with the OSHA Reference Method or an equivalent counting method [see 29 CFR 1926.1101 Appendix A]. Unless the method meets the monitoring equivalency criteria in [1926.1101(f)(2)(ii)], the use of real-time monitoring instruments as the basis for PPE selection for protection against asbestos is **not** permitted, and PPE cannot be downgraded during emergency response operations involving asbestos exposure until appropriate sampling data are available.

Where asbestos is the only hazardous substance present, you may follow the specifications in the asbestos standards with regard to PPE selection. If the airborne concentration of asbestos fibers is unknown, then full facepiece, supplied air respirators operated in pressure demand mode and equipped with auxiliary positive pressure self-contained breathing apparatus shall be used [see 29 CFR 1926.1101(h)(3)(I)]. This level of PPE is required until appropriate air monitoring results indicate that a lesser level of respiratory protection is adequate.

Where other inhalation hazards may be present along with asbestos, you must comply with paragraph (q)(3)(iv) of 29 CFR 1910.120, which requires that emergency responders exposed or potentially exposed to an inhalation hazard shall wear self-contained breathing apparatus (SCBA) until air monitoring results indicate that a lesser level of respiratory protection is adequate. Where accurate direct reading instruments are available for the substance in question, HAZWOPER permits their use as the basis for selection/downgrading of PPE, unless another applicable standard (i.e., a substance-specific expanded health standard) specifies a more protective approach.

We hope this information is helpful. If you have any further questions please contact us at (202) 219-8036.

Sincerely,

Ruth E. McCully, Director
Office of Health Compliance Assistance

CHAPTER 5

Personal Protective Equipment: Respirator Types, Caring for Your Respirator, and Other Safety Equipment

Learning Objectives

In Part 1 you will learn ...

- ❶ What respirators are and how they work.
- ❷ You must wear a respirator when you work with asbestos.
- ❸ Respirators are not perfect.
- ❹ Respirators have to fit.
- ❺ What respirators are allowed on an asbestos job.
- ❻ What respirators are not allowed on an asbestos job.
- ❼ How to figure out if you have the right respirator for the job.

In Part 2 you will learn ...

- ❽ What your employer has to do before giving you a respirator:
 - ❶ How to make sure your respirator fits;
 - ❷ How to take care of your respirator; and
 - ❸ How to clean, inspect, maintain, and store your respirator.

In Part 3 you will learn ...

- ❾ About disposable suits.
- ❿ About hard hats, boots, and other safety equipment.

TIME: 3:15 min including :15 min break at the end of the classroom session and :15 min break at the end of the hands - on session

INCLUDES: What is and isn't a legal respirator for asbestos abatement work; why a respirator is as good as its fit; not everyone can wear a respirator; who, on an asbestos job, must wear a respirator; which respirator works with which asbestos class of work activity (Class I - IV); respirator types: half-face, APR; full-face, APR; full-face, tight-fitting PAPR; Type C Continuous Flow SAR; and Type C Positive-Pressure, Pressure-Demand SAR and SCBA; and Type C system requirements; protection factors; MUL and its calculation; the employer's mandatory respirator program; employee's responsibility under the respirator program; typical parts of an APR; fit-testing; seal checks; cleaning and storage of a respirator; disposable suits; footwear; gloves, taping, hard hat; *Respirator Activity*; *Discussion Questions Activity*; *Respirator Exercise*; referencing *Key Facts*; and Respirator/PPE hands-on Activity

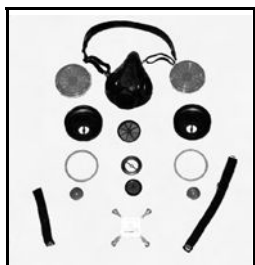

METHODS: Q&A; Lecturette; SGA; Demonstration; Hands-on

MATERIALS: Chapter 5, pp. 247 - 285, Chapter 1, pp. 14-15, (*AWM*); *Respirator Activity*, pp. 247 -248; optional *Discussion Questions*, p. 281; *Respirator Exercise*, p. 282; slides: Tray 1-100 thru 138 or PPT *05 PPE* (see Chapter 12 for slide script: PP 1-38); see Chapter 8 for *Glossary* (pp. 328 - 341) and *Acronyms* (p. 342); Chapter 11, pp. 18 - 20 for specs on hands-on structures; qualitative fit-testing kits (irritant smoke and Bitrex®); irritant smoke tubes; optional quantitative fit test kit – Portacount®; Rainbow Passage; respirator repair box; class set of surgical gloves; four (4) wash tubs; small bottle of Clorox®; sanitizer; class sets of paper towels; a full-face APR (if in







the box); tight-fitting PAPR; class set of half-face APRs w/bags; class set of HEPA filters; (optional: class set of the following PPE: Tyvek® suits, plastic boot covers, goggles, cotton gloves, and duct tape;) 4 - 5 tables covered with poly; chairs and/or benches for dress-out; disposal bags; and access to hot running water





Choice or combination of: white board/chalk board/flip chart, overhead projector, video player, screen; **AWM**; white board markers and cleaner, chalk and eraser, flip chart pad and markers, overhead transparencies (OHTs), markers, and spare projection bulb; PowerPoint (PPT) or similar program, computer, projector (slide and/or LCD), spare bulbs, and connecting cords; batteries for remotes/laser pointers; and extension cords (GFCI preferred); **optional:** masking tape, three-prong electrical adapters, and Leatherman tool or equivalent ... **Note:** avoid confusion among the various types of markers (overhead, white board, and flip chart) and do not write on the projection screen

TIME	METHOD	MATERIALS
:03	Outline learning objectives	Verbal or use of audio/visual teaching aid (i.e., OHT, flip chart, or PPT; screen)
:02	Provide overview of topics and teaching methods for the lesson	Verbal or use of audio/visual teaching aid (i.e., OHT, flip chart, or PPT; screen)





TIME	METHOD	MATERIALS
:08	<p>Ask for volunteers to read the skit, <i>Respirators...</i>, and then discuss ...</p> <p style="text-align: center;">SKIT DISCUSSION GUIDE Questions & Possible Answers</p> <p>Q: <u>How do you know what type mask you need?</u></p> <p>A: “Ask the industrial hygienist. It’s her job,” “The mask that the company give you is the only one you’re going to get. So why bother trying to figure it out?” “The supervisor tells you,” “Ask the supplier. They can tell you,” “Look at the lab report.”</p> <p>Q: <u>Do you think half-masks are good enough for the job? Why or why not?</u></p> <p>A: “A half-mask is good for any asbestos work,” “You should only use a half-mask for setup. You need a PAPR for removal,” A half-mask might be OK, but it has to work right and it has to fit.”</p> <p>Q: <u>Should Nick go ahead and use the half-mask?</u></p> <p>A: “Yes, otherwise he’ll get fired,” “No, he should talk to the supervisor and ask for the right mask,” “Yes, even if the mask isn’t exactly what he needs, it will protect him enough,” “No, he should get the right or walk off the job.”</p>	<p>AWM pages 247-248; Q&A with choice of and/or combination of teaching aids (OHTs, flip charts, white board, or PPT; screen); markers; laser pointer</p> <div style="text-align: right;">  </div>

TIME	METHOD	MATERIALS
	<p>Q: <u>Why doesn't this contractor post air-monitoring results sooner?</u></p> <p>A: The contractor can't get them any sooner," "It wouldn't make any difference. The only one who knows how to read the lab reports is the industrial hygienist," "Contractor wants to save money. The shorter the turn-around time, the more the lab charges."</p> <p>Q: <u>Does Bobby have a right to see the air sampling results from the job site?</u></p> <p>A: "Yes."</p>	
<p>:60</p>	<p>Show slides and use as triggers for open-ended questions and close-ended knowledge-specifics found in Chapter 5. Identify and teach these key topics:</p> <ul style="list-style-type: none"> ➤ What is and isn't a legal respirator for asbestos abatement work; ➤ Why a respirator is as only as good as its fit; not everyone can wear a respirator; ➤ Who, on an asbestos job, must wear a respirator; ➤ Which respirator works with which asbestos class of work activity (Class I - IV); ➤ Respirator types: half-face, APR; full-face, APR; full-face, tight-fitting PAPR; Type C Continuous Flow SAR; and Type C Positive-Pressure, Pressure-Demand SAR and SCBA; and Type C system requirements; <u>demonstration</u> 	<p>Slide Tray 1-101 thru 138 or PPT <i>05 PPE</i> (see Chapter 12 for slide script: PPE 1-38); slide or LCD projector, screen, remote and laser pointer; AWM pages 248 – 267, 271-280, and 283-285; lecturette, Q&A, discussion, and demonstration with choice of and/or combination of teaching aids</p>

TIME	METHOD	MATERIALS
	<ul style="list-style-type: none"> ➤ Protection factors; ➤ MUL and its calculation; ➤ The employer's mandatory respirator program; ➤ Employee's responsibility under the respirator program; ➤ Typical parts of an APR; ➤ Fit-testing; ➤ Seal checks; ➤ Cleaning and storage of a respirator; and ➤ Disposable suits; footwear; gloves, taping, hard hat 	<p>(OHTs, flip charts, white board, or PPT; screen); markers; laser pointer; masking tape; half-face & full-face APR; PAPR; Tyvek suit; goggles; surgical & cotton gloves; and boot covers</p>
	<p><u>OPTIONAL:</u> Use <i>Discussion Questions</i> as a summary tool (close-ended questions) and as a device to connect or expand on information learned in Part 2</p> <p style="text-align: center;">DISCUSSION GUIDE Questions & Possible Answers</p> <p>Q: <u>The law gives you the right to go through decontamination and wash your facpiece is asbestos or your respirator irritates it. Why do you have this right?</u></p> <p>A: A respirator protects you if it fits you and you have a good seal. When wearing a tight fitting respirator, you must have a good seal. A good seal between your face and your respirator keeps asbestos fibers out of your breathing space. When working, your face may feel irritated</p>	<p>AWM page 281; Q&A and discussion with choice of and/or combination of teaching aids (OHTs, flip charts, white board, or PPT; screen); markers; laser pointer</p> <p style="text-align: right;">↔</p>

TIME	METHOD	MATERIALS
	<p>by asbestos, sweat, dust, or even the respirator itself. The law states that you can leave the work area, go through decontamination, and wash your face to protect you.</p> <p>Q: <u>When you first pick up your respirator, what are you going to do?</u></p> <p>A: When you first pick up your respirator, you want to check to make sure that it is the exact rand, model, and size respirator that you were fit-test for. Then you want to inspect your respirator each time you go to put it on. Make sure the inhalation and exhalation valves are where they're supposed to be and are in good shape. Look for splits, cracks, or dimpled areas on your respirator. Check the harness and crown, filters or cartridges, and the cleanliness of your respirator.</p> <p>Q: <u>How often do you need a fit test?</u></p> <p>A: Each time you receive a new respirator, you must get a fit test on that respirator. Anytime the shape of your face changes, you need a fit test. If you break your nose, or lose some teeth, or gain or lose 15% or so in body weight, the shape of your face may change. Barring no physical changes, you fit test every year for each type of respirator you wear.</p>	 

TIME	METHOD	MATERIALS
	<p>Q: <u>Why is it important to learn how to do the positive and negative pressure fit checks?</u></p> <p>A: These fit (seal) checks are the test you do every time you put on your respirator. You do these checks anytime your respirator gets bumped or moved. You use these checks to make sure that you have your respirator on the right way.</p>	
:12	<p>SGA = break the class back into their small groups of 3-4 students and assign each group one of the questions from the <i>Respirator Exercise</i>. Give them five minutes to come up with the answer. Have then give the answer to the class as you read the question.</p>	<p>AWM; Respirator Exercise w/answers on page 282; Q&A and discussion with choice of and/or combination of teaching aids (OHTs, flip charts, white board, or PPT; screen); markers; laser pointer</p>
:5	<p>Review Respirator Types Key Facts; Caring for Your Respirator Key Facts; and Other Protective Equipment Key Facts.</p>	<p>AWM pages 268 - 269, 280, and 285; Verbal or use of audio/visual teaching aid (i.e., OHT, flip chart, or PPT; screen)</p>

TIME	METHOD	MATERIALS
:73	<p>Hands-on Activity: Session trainer(s) will demonstrate one or more fit testing protocols and how to wash a respirator; students will select their own half-face respirator (to be used for the duration of the course); inspect it, don it, adjust the straps/crown, negative and positive seal check the respirator twice; and doff the respirator. At the discretion of the CPP (Chief/Course Paper Pusher), a dress-out hands-on will be done with the students putting on a Tyvek® suit, plastic boot covers, surgical and cotton gloves, and goggles.</p>     	<p>Qualitative fit-testing kits (irritant smoke and Bitrex®); irritant smoke tubes; optional quantitative fit test kit – Portacount®; Rainbow Passage; respirator repair box; class set of surgical gloves; four (4) wash tubs; small bottle of Clorox®; sanitizer; class sets of paper towels; class set of half-face APRs w/bags; class set of HEPA filters; (optional: class set of the following PPE: Tyvek® suits, plastic boot covers, goggles, cotton gloves, and duct tape;) 4 - 5 tables covered with poly; chairs and/or benches for dress-out; disposal bags; and access to hot running water</p>

TIME	METHOD	MATERIALS
:02	Summarize session's objectives to refresh the participants about the learning goals achieved during the previous 2:45	Lecturette with choice of and/or combination of teaching aids (OHTs, flip charts, white board, or PPT; screen); markers; laser pointer

Respirator Drying Rack

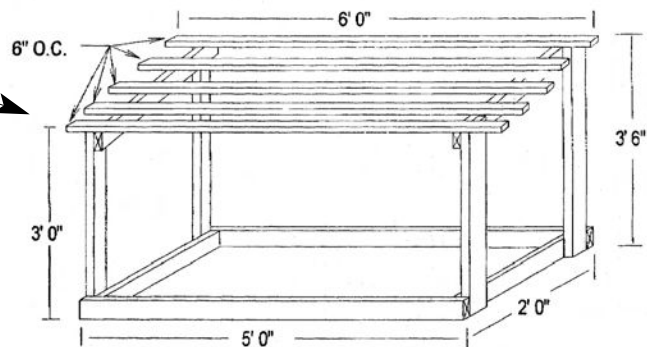

MATERIAL NEEDED.

- 2 - 2" X 4" X 21"
- 2 - 2" X 4" X 60"
- 2 - 2" X 4" X 36"
- 2 - 2" X 4" X 42"
- 5 - 1" X 2" X 72"

Wash/Rinse Table

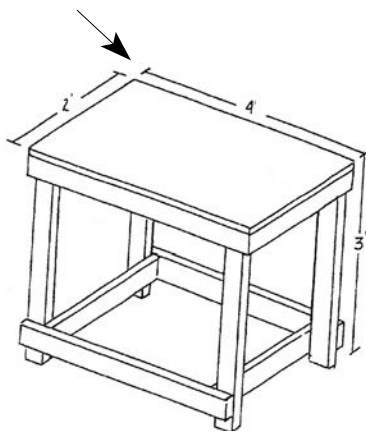

Bench

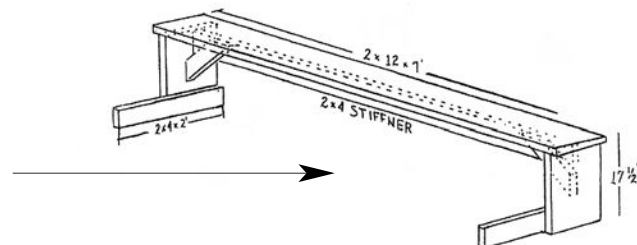

CHAPTER 6

Cleanup & Disposal

Learning Objectives

After this lesson, you will be able to...

- ❶ How to clean up the work area.
- ❷ How to take down the poly on the walls and floor.
- ❸ What happens to asbestos after it leaves the job.
- ❹ How your employer tests the air at the end of the job.

TIME: :45 min

INCLUDES: Cleanup asbestos you can see; Lockdown the asbestos you don't see; Take down the first two layers of poly; Waste Disposal; Cleaning tools; Testing the air at the end of the job; Sprayback; Re-insulation; Storage, Transportation, and Disposal; Labeling; Chain of Custody; *Cleanup ... Activity*; **SAMPLE QUESTIONS - ADDITIONAL Discussion Questions**; *Discussion Questions*; referencing *Key Facts*

METHODS: Question & Answer; Lecturette; Small Group Activity

MATERIALS: Chapter 6, all (*AWM*); *Cleanup ... Activity*, pp. 287 - 288; optional **SAMPLE QUESTIONS - ADDITIONAL DISCUSSION QUESTIONS**, p. 296 - 297; optional

Discussion Questions, p. 299; slides Tray 2-1 thru 38 or PPT *06 Waste Disposal* (see Chapter 12 for slide script: WD 1-21) and PPT *07 Lockdown & Sprayback* (see Chapter 12 for slide script: LDSB 1-17); see Chapter 8 for *Glossary* (pp. 328 - 341) and *Acronyms* (p. 342)





Choice or combination of: white board/chalk board/flip chart, overhead projector and screen/ PowerPoint program and projector; *EPA Model Asbestos Worker Training Manual (AWM)*; white board markers and cleaner, chalk and eraser, flip chart pad and markers, overhead transparencies (OHTs), markers, and spare projection bulb; PowerPoint (PP) or similar program, computer, projector, spare bulb, and connecting cords; batteries for remotes and extension cords (GFCI preferred); **optional:** masking tape, duct tape, three-prong electrical adapters, and Leatherman tool or equivalent. **Note:** avoid confusion among the various types of markers and do not write on the projection screen.

TIME	METHOD	MATERIALS
:2	Outline learning objectives	Verbal or use of audio/visual teaching aid (i.e., OHT, flip chart, or PPT; screen)
:1	Provide overview of topics and teaching methods for the lesson	Verbal or use of audio/visual teaching aid (i.e., OHT, flip chart, or PPT; screen)

TIME	METHOD	MATERIALS
:08	<p>Ask for volunteers to read the skit, <i>Cleanup ...</i> and then discuss ...</p> <p style="text-align: center;">SKIT DISCUSSION GUIDE Questions & Possible Answers</p> <p>Q: <u>Is it OK to use a regular shop vacuum to clean up asbestos as long as you are inside an enclosure? Why or why not?</u></p> <p>A: “Yes, as long as you have a good respirator,” “No, you’ll kick up asbestos dust,” “ No, filters won’t trap the asbestos and you will blow the dust into the air.”</p> <p>Q: <u>Do you need to worry about kicking up asbestos dust inside the containment? Why or why not?</u></p> <p>A: “Yes, your respirator won’t filter out all the fibers so you have to try to keep them out of the air,” “No, the negative air machine will take all the asbestos out of the air pretty quickly.”</p> <p>Q: <u>If Phil uses the shop vac, how could it affect the people on the next shift?</u></p> <p>A: “It wouldn’t affect them at all,” “The fiber levels will be higher than they expect when they come in. Their respirators may not protect them against such a high level,” “Phil shouldn’t worry so much.”</p>	<p>AWM pages 287-288; Q&A with choice of and/or combination of teaching aids (OHTs, flip charts, white board, or PPT; screen); markers; laser pointer</p> <p style="text-align: right;">↔</p>

TIME	METHOD	MATERIALS
	<p>Q: <u>How could it affect the next person who uses the shop vac?</u> A: “It couldn’t affect them at all,” “Every time they use it they’ll be exposed to asbestos.”</p>	
:25	<p>Show slides and use as triggers for open-ended questions and close-ended knowledge-specifics that can be found in Chapter 6. Topics to be covered include:</p> <ol style="list-style-type: none"> ① Cleanup asbestos you can see; ② Lockdown the asbestos you don’t see; ③ Take down the first two layers of poly; ④ Waste Disposal; ⑤ Cleaning tools; ⑥ Testing the air at the end of the job; ⑦ Sprayback; ⑧ Re-insulation; ⑨ Storage, Transportation and Disposal; and ⑩ Labeling and Chain of Custody 	<p>Slide Tray 2-1 thru 38 or PPT <i>06 Waste Disposal</i> (see Chapter 12 for slide script: WD 1-21 & LDSB 1-17); AWM pages 288 – 295; lecturette, Q&A, and discussion with choice of and/or combination of teaching aids (OHTs, flip charts, white board, or PPT; screen); markers; laser pointer; masking tape</p>
	<p><u>OPTIONAL</u>: SGA = break the class back into their small groups of 3-4 students and assign each group two of the questions from the <i>SAMPLE QUESTIONS</i> activity. Give them only 6 minutes to come up with the answers. Have then give the answers to the class as you read the question.</p>	<p>AWM; SAMPLE QUESTIONS - Additional Discussion Questions w/answers on pages 296-297; slide or LCD projector, screen, remote and laser pointer; lecturette, Q&A, and</p>

TIME	METHOD	MATERIALS
		<p>discussion with choice of and/or combination of teaching aids (OHTs, flip charts, white board, or PPT; screen); markers; laser pointer; masking tape</p>
:5	<p>Review Cleanup and Disposal Key Facts</p>	<p>AWM page 298; Verbal or use of audio/visual teaching aid (i.e., OHT, flip chart, or PPT; screen)</p>
	<p><u>OPTIONAL:</u> Use <i>Discussion Questions</i> as a summary tool (close-ended questions) and as a device to connect or expand on information learned in the Cleanup & Disposal and Lockdown/ Sprayback session ...</p> <p style="text-align: center;">SKIT DISCUSSION GUIDE Questions & Possible Answers</p> <p>Q: <u>Why is it important to clean up the poly if it will be thrown out anyway?</u></p> <p>A: At the end of the job, poly on the walls and floors will have a lot of asbestos on it, even if it is cleaned everyday. When the poly is taken</p>	<p>AWM pages 299; Q&A with choice of and/or combination of teaching aids (OHTs, flip charts, white board, or PPT; screen); markers; laser pointer</p> <p style="text-align: right;">↔</p>

TIME	METHOD	MATERIALS
	<p>down, a lot of dust can come off. This can be dangerous for the workers and it also contaminates the room, making it harder for the job to pass the clearance air samples.</p> <p>Q: <u>Some people say that lockdown should not be used. They argue that cleanup should be done so well that lockdown is not needed. What do you think?</u></p> <p>A: The purpose of lockdown is to seal in any (invisible) fibers that are not cleaned off. However, even if they are lockdown, the fibers that remain can be a hazard to maintenance workers who later work on the beam, pipe, etc. Those who argue against lockdown say that it makes contractors lazy. Those who argue for lockdown say that it is not possible (or feasible) to clean up every fiber, so lockdown is necessary.</p> <p>Q: <u>After taking off most of the asbestos, a contractor spray painted the beams instead of cleaning them off. What is the problem with this?</u></p> <p>A: The contractor left a lot of asbestos on the beam. The fibers that remain can be a hazard for maintenance workers who later work on the beam, pipe, etc. In this actual case, an industrial hygienist caught a</p>	

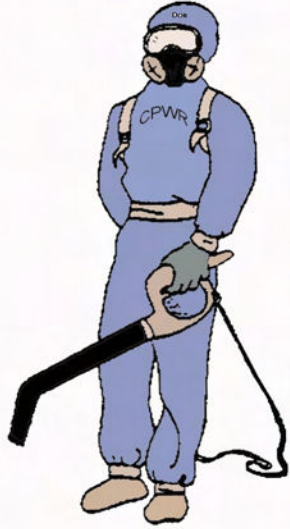
TIME	METHOD	MATERIALS
	<p>worker with a can of spray paint in his hand. The contractor had to remove all of the paint, properly clean the beam, and properly lock it down.</p> <p>Q: <u>Why is the air stirred up before clearance air samples are taken?</u></p> <p>A: Fans are used to push fibers off of floors and walls and into the air so that they can be counted. The air sampling pump cannot the fibers unless they are in the air. The aggressive air samples tell the building owner whether the room is clean enough to re-occupy.</p> <p>Q: <u>Why do you wait until after the job passes the air test to put up sprayback?</u></p> <p>A: Sprayback, or replacement material, must not contain asbestos. Sprayback could be contaminated by the asbestos in the room if the area is not clean when it is installed before the samples clear the way. This can happen easily on a roof or boiler job, and the like.</p> <p>Q: <u>In what order would you conduct the following clean up activities?</u></p> <p><u>2</u> Wet wiping/HEPA vacuuming first (Inside) layer of poly.</p> <p><u>6</u> Conduct visual inspection of the work area.</p> <p><u>9</u> Disassemble the decon unit.</p>	 <p style="text-align: right;">↔</p>

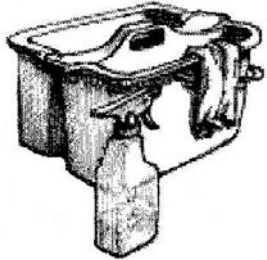
TIME	METHOD	MATERIALS
	<p><u>4</u> Wet wipe/HEPA vac the second (outside) layer of poly.</p> <p><u>5</u> Clean primary (critical) barriers.</p> <p><u>7</u> Conduct clearance air monitoring.</p> <p><u>8</u> Take down primary (critical) barriers.</p> <p><u>3</u> Spray a lockdown encapsulant on substrate surface and/or plastic.</p> <p><u>1</u> Remove all bags of waste from the work area.</p>	
:02	Summarize session's objectives to refresh the participants about the learning goals achieved during the previous :45	Lecturette with choice of and/or combination of teaching aids (OHTs, flip charts, white board, or PPT; screen); markers; laser pointer

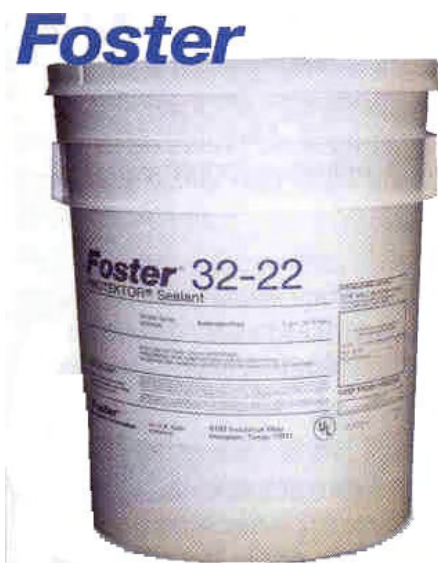

CHAPTER 7

Other Health & Safety Problems

Learning Objectives

In this chapter, you will learn about these dangers on asbestos jobs ...

- ☹ Problems with heat.
- ☹ Cuts and bleeding.
- ☹ Chemicals other than asbestos.
- ☹ Oxygen-deficient atmospheres.
- ☹ Slips, trips, and back injuries.
- ☹ Fires & Explosions.
- ☹ Noise.
- ☹ Burns.
- ☹ Shock.
- ☹ Tight spaces.
- ☹ Electrical shocks.
- ☹ Mold.
- ☹ Dangers from scaffolds and ladders.

TIME: :30 min

INCLUDES: Heat Stress; Cuts & Bleeding; Burns; Chemicals of other Asbestos; Oxygen Deficiency; Electrical Shocks; Noise; Fires & Explosions; Confined Spaces; Ladders; Scaffolds; Slips, Trips, and Falls; Shock, and Mold; *Safety Activity*; *Safety & Health Exercise*; referencing *Key Facts*

METHODS: Question & Answer; Lecturette; Small Group Activity

MATERIALS: Chapter 7, all (*AWM*); *Safety Activity*, pp. 301 - 302;

optional **Safety & Health Exercise**, pp. 324 - 325 -325; slides Tray 2-39 thru 59 or PPT *08 Other Safety Concerns* (see Chapter 12 for slide script: OSC 1-21); see Chapter 8 for *Glossary* (pp. 328 - 341) and *Acronyms* (p. 342)





Laser Pointer

Choice or combination of: white board/chalk board/flip chart, overhead projector and screen/ PowerPoint program and projector; *EPA Model Asbestos Worker Training Manual (AWM)*; white board markers and cleaner, chalk and eraser, flip chart pad and markers, overhead transparencies (OHTs), markers, and spare projection bulb; PowerPoint (PP) or similar program, computer, projector, spare bulb, and connecting cords; batteries for remotes and extension cords (GFCI preferred); **optional:** masking tape, duct tape, three-prong electrical adapters, and Leatherman tool or equivalent. **Note:** avoid confusion among the various types of markers and do not write on the projection screen.

TIME	METHOD	MATERIALS
:3	Outline learning objectives	Verbal or use of audio/visual teaching aid (i.e., OHT, flip chart, or PPT; screen)
:1	Provide overview of topics and teaching methods for the lesson	Verbal or use of audio/visual teaching aid (i.e., OHT, flip chart, or PPT; screen)

TIME	METHOD	MATERIALS
:08	<p>Ask for volunteers to read the skit, Safety ... and then discuss ...</p> <p style="text-align: center;">SKIT DISCUSSION GUIDE Questions & Possible Answers</p> <p>Q: <u>Who is right, the supervisor or Brian?</u> A: See next question</p> <p>Q: <u>Why did Brian take his mask off?</u> A: “Brian is stupid,” “It’s too hot in the work area,” “Brian’s the third person to take their respirator off that day. Something must be wrong with how they’re running the job,” “Brian is too lazy to work in the heat. He’s just making trouble,” “Brian doesn’t really know how dangerous asbestos is.”</p> <p>Q: <u>Is it OK to take your mask off in the containment?</u> A: “You should never take your mask off inside the containment,” “You should always keep your mask on. But sometimes when it’s really hot, you just can’t help having to take your mask off,” “It’s OK if you take it off and put it right back on. It’s not OK to take your mask off and then keep working without it.”</p> <p>Q: <u>What should you do if they have to take their masks off?</u> A: “They should go through the decon and shower,” “You can just go into the dirty room, wipe your face real</p>	<p>AWM pages 301-302; Q&A with choice of and/or combination of teaching aids (OHTs, flip charts, white board, or PPT; screen); markers; laser pointer</p> <div style="text-align: right;">  </div>

TIME	METHOD	MATERIALS
	<p>quick and put your mask right back on,” “Your supposed to decontaminate, but our contractor won’t give us the time to do that. The supervisor just looks the other way while we take our masks off for a second,” “It costs too much to use a new suit and filters every time you’ve got and itch. Workers have to wait until the break or take their masks off inside.”</p> <p>Q: <u>What could the company do to make it easier for workers to keep their masks on?</u></p> <p>A: “They could keep reminding the workers how dangerous it is to breathe asbestos” or “They could buy PAPRs like the workers asked for,” “They could hire a larger crew.”</p> <p>Q: <u>What could the supervisor do?</u></p> <p>A: “S/he could give more breaks when it’s hot,” “Work could be scheduled for the coolest part of the day,” “Plan to rotate workers so that nobody is doing really hot work for more than a few hours a day.”</p> <p>Q: <u>What would you do if you were Brian?</u></p> <p>A: “I’d take off my respirator when the supervisor wasn’t looking,” “I’d just keep the mask on and keep working. Heat is uncomfortable, but it’s not a serious hazard,” (wrong) “I’d talk with the other workers who had the</p>	

TIME	METHOD	MATERIALS
	<p>same problem and have them all talk with the supervisor,” “I’d walk off the job,” or “I’d call the union rep.”</p> <p>Q: What would you do if you were the supervisor?</p> <p>“At the next toolbox meeting, I’d tell the workers about how dangerous asbestos is and how important it is to keep their masks on,” “I’d write Brian up and fire the next one who takes off a mask. After all, if the company gets cited, it’s the supervisor who gets in trouble,” “I’d ask the company for PAPRs,” and “I’d ask the company for a larger crew.”</p>	
	<p>Show slides and use as triggers for open-ended questions and close-ended knowledge-specifics that can be found in the Chapter 7. Topics to be covered include:</p> <ul style="list-style-type: none"> ⊗ Problems with heat. ⊗ Noise. ⊗ Cuts and bleeding. ⊗ Burns. ⊗ Chemicals other than asbestos. ⊗ Shock. ⊗ Oxygen-deficient atmospheres. ⊗ Tight spaces. ⊗ Slips, trips, and back injuries. ⊗ Electrical shocks. ⊗ Fires & Explosions. ⊗ Mold. 	<p>Slide Tray 1-2 thru 39-59 or PPT 08 <i>Other Safety Concerns</i> (see Chapter 12 for slide script: OSC 1-21); slide or LCD projector, screen, remote and laser screen); markers; pointer; AWM pages 303 – 321; lecturette, Q&A, and discussion with choice of and/or combination of teaching aids (OHTs, flip charts, white board, or PPT; laser</p>

TIME	METHOD	MATERIALS
	⊗ Dangers from scaffolds and ladders.	pointer; masking tape
	Use Other Safety and Health Problems Key Facts as a summary tool as device to connect to knowledge gained in this learning session.	AWM pages 322 - 323 ; lecturette
	OPTIONAL: SGA = break the class back into their small groups of 3-4 students and assign each group two of the questions from the <i>Safety and Health Exercise</i> . Give them only six minutes to come up with the answers. Have them give the answers to the class as you read the question.	AWM; Safety and Health Exercise, w/ answers on pages 324 - 325 ; Q&A and discussion with choice of and/ or combination of teaching aids (OHTs, flip charts, white board, or PPT; screen); markers; laser pointer
:02	Summarize session's objectives to refresh the participants about the learning goals achieved during the previous :30 min	Lecturette with choice of and/or combination of teaching aids (OHTs, flip charts, white board, or PPT; screen); markers; laser pointer



Glovebagging & Plasticizing Principles & Procedures

Learning Objectives

In this lesson, you will learn ...

Glovebagging:

- ① How to set up a pipe and a glovebag for a repair.
- ② How to remove pipe covering and seal the exposed end.
- ③ How to handle a sprayer during a glovebag repair.
- ④ How clean a glovebag after a repair and remove it from a pipe.
- ⑤ How to remove tools from a sealed glovebag following a repair.
- ⑥ How to remove air from a glove bag with a HEPA vacuum while the bag is on the pipe.
- ⑦ How to remove sealed tools safely from a bucket of water.
- ⑧ How to bag and glovebag waste and seal the waste bag using a HEPA vacuum and the goosenecking taping technique.

Plasticizing:

- ① How to measure poly requirements for critical barriers, floor poly and wall poly.
- ② How to make duct tape tabs and pull long lengths of duct tape.
- ③ How to cut, fold, and crease floor poly
- ④ How to install floor poly as a single sheet or as two seeded sheets.
- ⑤ How to install critical barriers.

TIME: 2:15 min including :15 min break

INCLUDES: Instructor demonstration of setting up a glovebag, completing a repair, and cleaning up; Instructor demonstration of plasticizing principles for critical barrier, one piece poly floor layer, 2-piece poly seaming of floor, chalk line; and 3 wall-sides w/1-piece poly

METHODS: Question & Answer; Lecturette; Demonstration

MATERIALS: Chapter 4 pp. 235 - 242 (**AWM**); slides Tray 2-60 to end PPT *09 Glovebagging and Plasticizing* (see Chapter 12 for slide script: OSC 1-63 [the "OSC" is a typo in the script])

Glovebag stand w/pipe covering, glovebag, duct tape, water bucket, low-pressure sprayer, utility knives (2), bone saw (optional); repair material (plaster wrap), scrubbie, HEPA vacuum; waste bag (2), cubicle setup, poly for floor; tape measure, scissors, protective eye wear, spray glue, staplers (optional), smoke tube set





Choice or combination of: white board/chalk board/flip chart, overhead projector and screen/ PowerPoint program and projector; *EPA Model Asbestos Worker Training Manual (AWM)*; white board markers and cleaner, chalk and eraser, flip chart pad and markers, overhead transparencies (OHTs), markers, and spare projection bulb; PowerPoint (PP) or similar program, computer, projector, spare bulb, and connecting cords; batteries for remotes and extension cords (GFCI preferred); **optional:** masking tape, duct tape, three-prong electrical adapters, and Leatherman tool or equivalent. **Note:** avoid confusion among the various types of markers and do not write on the projection screen.

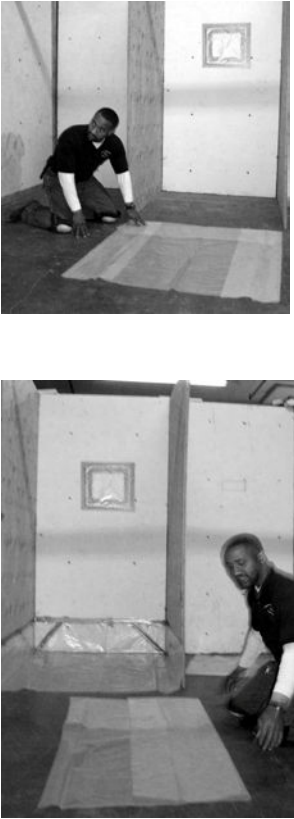

TIME	METHOD	MATERIALS
:2	Outline learning objectives	Verbal or use of audio/visual teaching aid (i.e., OHT, flip chart, or PPT; screen)
:1	Provide overview of topics and teaching methods for the lesson	Verbal or use of audio/visual teaching aid (i.e., OHT, flip chart, or PPT; screen)
2:12	Show slides of glovebagging and plasticizing (critical barrier, 2 floors, and 1 wall sheet (3 wall sides). Refer to Chapter 4 for questions if needed. Take the class to the shop where glove bagging stands, cubicles, tools, PPE, and supplies await them. A seamed glove bag is ready for use, and the pipe has anchor points prepared.	Slide Tray 2-60 to end; <i>Glove bagging and Plasticizing</i> (see Chapter 12 for slide script: OSC 1-63; slide or LCD projector, screen,

TIME	METHOD	MATERIALS
	<p>Two instructors or an instructor and a student start the demonstration by placing tools (knife, scrubbie, repair material, bone saw) into the pouch in the glovebag. The glove bag is then secured to the pipe using spray glue and duct tape. The glovebag is tested for leaks with a smoke tube and then a port is prepared for a wand from a low-pressure sprayer. The “helper” wets down the damaged pipe cover and the “lead” worker removes a knife from the pouch and scores the pipe covering where the damaged material is to be cut away. After placing the knife back in the tool pouch, the <i>lead</i> uses a bone saw to completely cut the circumference of the pipe covering. The helper is lightly spraying the repair area. Once the damaged material is cut away and placed at the bottom of the bag, the newly revealed pipe is cleaned with a scrubbie from the tool pouch. The <i>lead</i> then smoothly applies the plaster wrap repair material. The bag is wet again and the scrubbie is used to wipe the bag down. The bag is tested for leaks before being removed. Tools are removed from the glovebag and placed in a bucket of water. The wand port is made wider and a HEPA vacuum hose is inserted into the glovebag where it is then collapsed. The bag below the pipe is twisted tight and taped. The HEPA vac hose is</p>	<p>remote and laser pointer; AWM pages pp. 235 - 242; lecturette, Q&A, discussion, and demonstration with choice of and/or combination of teaching aids (OHTs, flip charts, white board, or PPT; screen); markers; laser pointer; masking tape; glovebag stand w/pipe covering; glovebag; duct tape; water bucket; low-pressure sprayer; utility knives (2); bone saw (optional); repair medium (plaster wrap); scrubbie; lockdown spray (optional); HEPA vacuum; waste bag; cubicle setup; poly for floor; tape measure; scissors; protective eye wear; staplers (optional); spray glue; power cords; smoke tube</p>

TIME	METHOD	MATERIALS
	<p>removed and the top of the glove bag is split open with the second knife which has been kept outside. The bag drops gently into a waste bag being held just below it. The HEPA vac is used to collapse the waste-containing bag, and the bag is then goose-necked. A second waste bag is used for waste other than the glovebag (i.e., floor poly beneath the glovebag, anchor point tape, and bag hand) after tools are removed underwater in a bucket from the severed bag hand. This waste bag is collapsed as well.</p> <p>Plasticizing is then demonstrated with either one or two instructors, or an instructor and a student. Students are move to the plasticizing cubicles where one cubicle is setup for demonstration. One of the walls is pre-set with two duct taped layers of 6 mil poly properly covering a simulated HVAC vent or and electrical outlet. A pre-cut single piece of 6 mil floor poly has been pre-folded in on three sides (1' or 12"), creased, and set for demonstration. Either both or one of the outside edges of the cubicle contains a dozen or more duct tape tabs. The prepared floor poly is slid on the floor into the demo cubicle until it reaches the back wall. The three sides of creased poly are lifted and placed against the wall where they are tabbed and taped. Corners with 45° angles automatically form. All outside edges are smoothly duct taped. New tabs</p>	

TIME	METHOD	MATERIALS
	<p>are prepared a three-wall one piece 6 mil poly is put up. More tabs are made. Two pre-cut and pre-folded (creased) second floor-layer pieces are shown to the class. The folds, on two sides (one being the back), are 18". When placed in the cubicle, neither piece covers the entire floor. It takes two seamed pieces. One second floor piece is slid into the cubicle, its two sides tabbed, and then taped along all edges. The remaining second floor piece is slid in, tabbed, and taped. Before the second floor piece's floor edge is taped, a chalk line is applied or simulated to its underside. Then the last remaining edge is taped.</p> <p>The dimensions for the poly pieces (except for the critical barriers) are written on the cubicle stand for easy reference. Questions are answered during and after both the demonstrations.</p> <p style="text-align: center;">Hands-on is now on deck.</p>	



Hands-On: Plasticizing & Glovebagging

Learning Objectives

After this hands-on lesson, you will be able to demonstrate how to:

- ① Measure and cut poly;
- ② Repair damaged pipe covering using a glovebag;
- ③ Set up critical barriers;
- ④ Apply two layers of floor poly, the second layer being seamed;
- ⑤ Apply one layer of wall poly;
- ⑥ Construct a decontamination line; and
- ⑦ Collapse and seal an asbestos waste bag.

TIME: 7:30 including two :15 min breaks

INCLUDES: Hands-on Activities: Setup Plasticizing; Decon Construction; Glovebagging

METHODS: Coaching; Hands-on

MATERIALS: Glovebag stands w/pipe coverings; glovebags; rolls of duct tape; water buckets; low-pressure sprayers; utility knives (2/glovebag) and for Setup plasticizing; bone saws (optional); repair medium (plaster wrap); scrubbies;

lockdown spray (optional); HEPA vacuum; waste bags; cubicle setup; 6 mil poly for floor and walls; tape measures; gloves; scissors; protective eye wear; spray glue; staplers (optional); power cords; smoke tubes;
Checklist for Asbestos: Worker Hands-on Learning (AWM) Chapter 11, pp. 57 - 63



TIME	METHOD	MATERIALS
:05	Students are divided into pairs and then into 2 or 3 instructor-lead groups based on class size. The primary groups are Setup Plasticizing and Glovebagging . The third group, if formed, is Decontamination Line . When only two groups are used, Decon Line Construction is a rollover or holding area for pairs of students when completed with activity and are awaiting a spot in the other activity.	Lecturette

TIME	METHOD	MATERIALS
6:55	<p>Using the <i>Hands-on Evaluation Checklist</i> (Chapter 11, pp. 57 - 63), trainers direct their pairs of students toward efficient and quality achievement of tasks; giving positive support and/or redirection whenever possible. This checklist will be used later during the course for a final hands-on competency for each student. Directions for framing the PVC decon prior to the start of the hands-on activities are in Chapter 11, starting on page 3; the glovebag stand plans are on page 11, and the cubicles plan are on page 19.</p> <p>The <i>Hands-on Evaluation Checklist</i> details the tasks for all the activities. Turn to the <i>Checklist</i> for a detailed view of work to be done by the students.</p> <p>Students begin the hands-on training properly and fully dressed-out in PPE with the exception that there aren't any filters in their respirators. The students start "coming out" of their PPE based on heat, humidity, and the frustration factors of gloves/tape and fogging goggles/vision.</p>	<p>Glovebag stands w/pipe coverings; glovebags; rolls of duct tape; water buckets; low-pressure sprayers; utility knives (2/glovebag) and for Setup plasticizing; bone saws (optional); repair medium (plaster wrap); scrubbies; lockdown spray (optional); HEPA vacuum; waste bags; cubicle setup; 6 mil poly for floor and walls; tape measures; scissors; gloves; protective eye wear; spray glue; staplers (optional); power cords; smoke tubes; Chapter 11 (<i>AWM</i>); <i>Coaching</i>; <i>Demonstration</i></p>







Hands-On: Competency Evaluation

Learning Objectives

After this hands-on lesson, you will be able to demonstrate how to:

- ① Measure and cut poly;
- ② Repair damaged pipe covering using a glovebag;
- ③ Set up critical barriers;
- ④ Apply two layers of floor poly, the second layer being seamed;
- ⑤ Apply one layer of wall poly;
- ⑥ Construct a decontamination line; and
- ⑦ Collapse and seal an asbestos waste bag.



TIME: 3:15 min including one :15 min break

INCLUDES: Hands-on Activities Competency Evaluation

METHODS: Visual/Written Evaluation on hands-on activity

MATERIALS: Glovebag stands w/pipe coverings; glovebags; rolls of duct tape; water buckets; low-pressure sprayers; utility knives (2/glovebag) and for Setup plasticizing; bone saws (optional); repair medium (plaster wrap); scrubbies;

lockdown spray (optional); HEPA vacuum; waste bags; cubicle setup; 6 mil poly for floor and walls; tape measures; gloves; scissors; protective eye wear; spray glue; staplers (optional); power cords; smoke tubes;
Checklist for Asbestos: Worker Hands-on Learning (AWM) Chapter 11, pp. 57 - 63

TIME	METHOD	MATERIALS
<p>3:00</p>	<p>After dressing-out and being evaluated individually by an instructor, students return to their partners and group and start the hands-on competency at the work station they went to first the day before. The Decon Line is worked on only if it hasn't been completed. The students are then observed as they glovebag, plasticize a cubicle, and properly enter a decon from the regulated area, remove their PPE, and exit. The area is cleaned once all the evaluations are completed.</p> <div style="display: flex; justify-content: space-around;">   </div>	<p><i>Checklist for Asbestos: Worker Hands-on Learning (AWM) Chapter 11, pp. 57 - 63</i>; Glovebag stands w/pipe coverings; glovebags; rolls of duct tape; water buckets; low-pressure sprayers; utility knives (2/glovebag) and for Setup plasticizing; bone saws (optional); repair medium (plaster wrap); scrubbies; gloves; lockdown spray (optional); HEPA vacuum; waste bags; cubicle setup; 6 mil poly for floor and walls;</p>

TIME	METHOD	MATERIALS
		<p>tape measures; scissors; protective eye wear; spray glue; staplers (optional); power cords; smoke tubes</p>

